



SENLAN INVERTER

USER'S MANUAL

SB100 Series Inverter

General-purpose and compact

Hope SenLan Science & Technology Holding Corp., Ltd

Contents

Preface	1
1 Precautions	3
1.1 Safety precautions	3
1.2 Other precautions	4
2 Specifications.....	7
3 Installation and Wiring	11
3.1 Installation of inverter.....	11
3.2 Installation and removal of parts.....	11
3.3 Peripherals and options.....	13
3.4 Wiring of inverter.....	15
3.5 Methods of suppressing EMI.....	19
4 Operation and Commissioning	21
4.1 Operation and display	21
4.2 Switching on the power for the first time	24
4.3 Quick commissioning and optimization of commissioning	24
5 Parameter Table.....	25
6 Parameter Description	34
6.1 F0 Basic parameters	34
6.2 F1 Accel/decel, start, stop and jog parameters	35
6.3 F2 V/F control parameters	37
6.4 F3 Motor parameters.....	39
6.5 F4 Digital input terminals and multistep frequencies.....	40
6.6 F5 Digital and relay outputs.....	43
6.7 F6 Analog and pulse frequency terminals.....	45
6.8 F7 Process PID parameters	49
6.9 Fb Protection functions and advanced settings.....	51
6.10 FC Keypad operation and display settings	55
6.11 FF Communication parameters.....	55
6.12 FP Fault history	59
6.13 FU Data monitoring.....	59
7 Troubleshooting	60
7.1 Faults and remedies.....	60
7.2 Alarms and remedies.....	62
7.3 Operation faults and remedies	63
8 Maintenance and After-sale service.....	64
8.1 Daily maintenance.....	64
8.2 Replacement of parts.....	65
8.3 Storage of the inverter.....	65
8.4 After-sale service	65

Preface

Thank you for purchasing our SenLan SB100 series inverters.

SB100 is a compact inverter adopting the optimized high-performance space vector control VVVF arithmetic and featuring elegant appearance, delicate circuit design, ingenious circuit design, simple and practical functions, and reasonable menu arrangements. With numerous advanced functions such as auto torque boost, slip compensation, vibration suppression, smooth start, stall prevention, deadband compensation, AVR, process PID and auto carrier frequency regulation, SB100 can meet most of the requirements for industrial control.

Please carefully read and understand this manual before installing, setting, tuning and maintaining the product. The technical specifications for the product may alter and the contents of this manual are subject to change without notice. Keep the manual until the inverter is discarded as useless.

Check after unpacking

Please check the following items after unpacking SB100 inverter. If there is any problem, contact us or our distributors.

Check items	Check method
If the product is exactly what you have ordered?	Check to see if the data on the nameplate of the inverter is consistent with those in your order form
If there is any damage on the product?	Observe the external appearance of the product. Check to see if it has got any damage during transportation.

Model description:

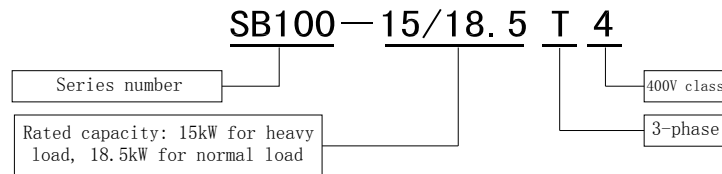



Nameplate description (take SB100-15/18.5T4 as an example):

SENLAN INVERTER		China Top Brand
Model: SB100-15/18.5T4	Standard: GB/T12668.2	
Rated input: 3-phase 380V 50/60Hz	Serial No.: 1234567	
Rated output: 3-phase 0~380V 0~650Hz		
Rated current: 30A/38A	Bar code	
Rated capacity: 15kW/18.5kW		
SenLan Inverter		Hope SenLan Science & Technology Holding Corp., Ltd.

Safety signs

The safety signs in this manual fall into two categories:

 **DANGER** : Indicates that errors in operation may destroy the inverter or lead to death or heavy injury to people.

 **CAUTION** : Indicates that errors in operation may lead to damage to the inverter or other devices.

1 Precautions

1.1 Safety precautions

1.1.1 Installation

- Do not install the inverter at a place with or near inflammable objects, otherwise there may be a risk of fire.
- Do not install the inverter in an environment with inflammable gases. That may cause explosion.

1.1.2 Wiring

- Make sure the high-voltage indicator is off and the DC link voltage is less than 36V, otherwise there may be a risk of electric shock.
- Make sure the input power is completely disconnected before the wiring is conducted, otherwise there may be a risk of electric shock.
- Do not connect a braking resistor between the DC terminals P+ and N-. That may cause fire.
- The voltage of the input power terminals should not beyond the rated voltage range. That may damage the inverter.
- The grounding terminal(PE) of the inverter must be securely connected to earth(resistance to earth $\leq 10\Omega$), otherwise there may be a risk of electric fire.

1.1.3 Check before switching on the power

- Close the cover board of the inverter before turning on the power, otherwise there may be a risk of electric shock or explosion.
- Before trying to run the motor at a frequency over the rated motor frequency, conform that the motor and the mechanical devices can endure such a high speed.

1.1.4 Precautions on power and operation

- Check to see if parameters are set appropriately before commissioning.
- Do not open the front cover while the input power is switched on, for the high voltage inside may cause electric shock.
- Do not handle the inverter with wet hands. That may lead to electric shock.
- “Power-on auto start” is enabled before the inverter is shipped from the factory. When the terminal control and the run signal are valid, the inverter will start automatically once the power is turned on.
- Do not control the run and stop of the inverter by switching on and off the input power.
- Related parameters should be reset after parameter initialization.
- If the function of restart has been set(such as fault auto-reset or restart after momentary power failure), do not approach the motor or mechanical load while the inverter is waiting to restart.

1.1.5 Precautions on transport and package

- Do not place more inverters than specified in the packaging box.
- Do not put any heavy object on the inverter.
- Do not open the cover board during transport.
- Do not apply any force on the keypad and the cover board while handling the inverter, otherwise there may be a risk of injury to people or damage to equipment.

1.1.6 Disposal

- Dispose the inverter as industrial waste.
- The electrolytic capacitors inside the inverter may explode while burned.
- Plastic components of the inverter will generate toxic gases while burned.

1.2 Other precautions

1.2.1 About motor and mechanical load

- Comparison with commercial power operation

SB100 inverter is a voltage-type PWM motor drive. Its output voltage contains some harmonics. Compared with the commercial power, it creates more loss and noise and leads to higher temperature rise of the motor.

The insulation withstand voltage of the cables and motor should be taken into account when the input voltage is high or the motor cables are long.

- Constant-torque, low-speed operation

When a common motor runs at low speed for a long time, the motor temperature will rise due to the weakening cooling effect. So if a motor is required to operate at low speed and constant torque for a long term, an inverter or the forced air cooling method must be used.

- Running above 50Hz

If you plan to run the motor over 50Hz, be aware that the vibration and noise will increase and make sure that the motor bearings and mechanical devices can withstand such a high speed.

- Lubrication of mechanical devices

While running at low speed for a long period, such mechanical devices as gearbox and gears may be damaged due to worsening lubricating effect. Before you run them, check the lubrication conditions.

- Regenerative torque load

Regenerative torque often occurs while a load is hoisted, and the inverter often stops due to overvoltage protection. In this case, an appropriate braking unit should be selected and installed.

- Mechanical resonant point

Certain output frequencies of the inverter may be the mechanical resonant points. To avoid these points, place anti-vibration rubber under the base of the motor or setting the jump frequencies.

- Motor insulation check before connected to the inverter

When the motor is used for the first time or reused after it has not been used for a long period, the motor insulation must be inspected to prevent the damage to the inverter cause by the failed insulation of the motor windings. Use a 500V voltage-type megaohm meter to measure the insulation resistance, which should not be less than 5MΩ.

 **DANGER** : **While performing the insulation test on the motor, be sure to disconnect the motor with the inverter, otherwise the inverter will be damaged.**

 **DANGER** : **Do not perform the voltage resistance test and insulation test on the control circuit, otherwise the circuit elements will be damaged.**

1.2.2 About inverter

- Capacitor or voltage-dependent resistor for improving power factor

As the inverter output is of PWM voltage type, the capacitor or voltage-dependent resistor(for improving the power factor) installed on the output side of the inverter will lead to inverter trip or damage to components. Do remove the capacitor or the voltage-dependent resistor before using the inverter.

- Frequent start and stop

For applications where frequent start and stop are needed, terminals are recommended for the control of the start/stop of the inverter. Using the switching device(such as contactor) on the inverter input side to start or stop the inverter frequently is prohibited. That may destroy the inverter.

- Using the inverter beyond the rated value

It is not recommended to operate the inverter beyond the range of the allowable input voltage. Use a voltage regulator to increase or decrease the voltage if required.

- Single-phase power input

If the 3-phase power input is changed to a single-phase power input, the ripples of the bus voltage and current will increase, which not only shortens the life of the capacitors, but also damages the performance of the inverter.

It is not recommended to turn the 3-phase into the single-phase. If single-phase is needed, the function of input phase loss protection must be disabled, and the inverter must be detuned with its max. value not greater than 60% of the rated value.

- Lightning protection

With the built-in protector against overvoltage caused by lightning, the inverter has certain self-protection ability against the lightning strike.

- Leakage protector

The high-speed switching operation during the running of the inverter will generate high-frequency leakage current which sometimes causes the mis-operation of the leakage protection circuit. To address this issue, moderately lower the carrier frequency, shorten the wires or install a leakage protector correctly.

Observe the following points while installing the leakage protector.

1 PRECAUTIONS

1) The leakage protector should be installed on the inverter input side, preferably behind the air switch(non-fuse circuit breaker).

2) The leakage protector should be one that is insensitive to higher harmonics or specially designed for the inverter(sensitivity above 30mA). If a common leakage protector is selected, its sensitivity and action time should be greater than 200mA and 0.2s, respectively.

■ Derating of inverter

1) If the ambient temperature exceeds 40°C, the inverter should be derated by 5% for every 1°C increase, and external forced cooling should be provided.

2) If the altitude is above 1000 meters, the inverter should be derated by 1% for every 100m rise.

3) If the carrier frequency is greater than the factory setting, the inverter should be derated by 5% for every 1kHz increase.

2 Specifications

2.1 Common specifications

Item		Description
Performance parameters	Input voltage & frequency	Rated voltage: 3-phase 380V; voltage range: 320 ~ 480V; voltage imbalance: <3% Frequency: 47~63Hz
	Output voltage & frequency	3-phase, 0V~input voltage, error<5% Frequency: 0.00~650.00Hz
	Overload capacity	110% 1min(150% 1min for heavy load)
	Frequency resolution	Digital reference: 0.01Hz Analog reference: 0.1% of max frequency
	Output frequency precision	Analog reference: $\pm 0.2\%$ of max frequency Digital reference: 0.01Hz
Control terminals	Communication	Built-in RS485 port, supporting Modbus protocol
	Analog input (AI)	2 channels(also used as digital input), voltage or current type, positive or negative, with drop detection
	Analog output(AO)	2 channels. One is voltage or current type, the other is PFO PWM output
	Digital input	7 channels of multi-function digital input(two of them are analog inputs, and one is PFI), sampling period 1ms
	Digital output	1 channel of NPN multi-function digital output(share with PFO) 2 channels of multi-function relay output(relay T2 can set opening and closing delay)
	Pulse frequency input(PFI)	Max input frequency 50kHz, used as frequency reference, PID reference, feedback, etc.(also used as digital input)
	Pulse frequency output(PFO)	0 ~ 50kHz, open collector pulse signal, frequency or PWM modulation(also used as AO or digital output)
Software functions	Motor control mode	Space vector V/F control, with auto torque boost and slip compensation
	Command source	Keypad, terminal and communication. They can be switched over by terminals
	Frequency reference source	Keypa(keys and POT), communication, UP/DOWN value, AI1, AI2 and PFI. Auxiliary frequency reference can be introduced for fine tuning
	V/F curve	Linear curve and two reduced-torque curves, with manual and auto torque boost
	Dynamic braking	Built-in braking unit and external braking resistor
	DC braking	Braking time: 0.0~60.0s Braking current: 0.0~100.0% of inverter rated current
	Accel/decel mode	Linear. Two sets of accel/decel time can be chose by terminals
	Jog	Jog frequency: 0.10~50.00Hz
	AVR	Keeps the output voltage constant automatically when the power grid voltage fluctuates
	Auto carrier frequency regulation	Carrier frequency is regulated automatically based on the load characteristics and ambient temperature
	Momentary power failure protection	Ensures uninterrupted operation after momentary power failure
	Process PID	Refer to Section 6.8 in Chapter 6
	Multistep frequency	7 multistep frequencies. Refer to F4-13~F4-19

2 SPECIFICATIONS

	Others	Smooth start, stall prevention, zero-speed delay, oscillation suppression, deadband compensation
Protection functions		Overcurrent, overvoltage, undervoltage, phase loss, output short-circuit, overheating, motor overload, external fault, analog input drop, stall prevention, etc.
Options		Keypad with direction key, keypad mounting box, keypad extension cable, braking resistor, input/output reactor, EMI filter, Profibus-DP module, remote control, etc.
Ambient	Service site	Altitude less than 1000 meters; indoor; no direct sunlight; free of dust, corrosive gases, inflammable gases, oil mist, water vapor, water drops, salt mist, etc.
	Temp/humidity	-10~+40°C/20~90%RH, no condensation
	Storage temp	-20~+60°C
	Vibration	Less than 5.9m/s ² (0.6g)
Structure	Protection degree	IP20
	Cooling method	Forced air cooling, with fan control(excluding SB100-0.4/0.55T4, which is naturally cooled)

2.2 Product series

Inverter model	Normal (110%I _N 1 minute for every 10 minutes)		Heavy load (150%I _{hd} 1 minute for every 10 minutes)	
	Rated current I _N (A)	Applicable motor (kW)	Rated current I _{hd} (A)	Applicable motor (kW)
SB100-0.4/0.55T4	1.8	0.55	1.5	0.4
SB100-0.75/1.1T4	3.0	1.1	2.5	0.75
SB100-1.5/2.2T4	5.1	2.2	3.7	1.5
SB100-3/4T4	9.7	4	5.5	3
SB100-3.7/5.5T4	12	5.5	9	3.7
SB100-5.5/7.5T4	17	7.5	13	5.5
SB100-7.5/11T4	24	11	18	7.5
SB100-11/15T4	30	15	24	11
SB100-15/18.5T4	38	18.5	30	15
SB100-18.5/22T4	45	22	38	18.5

Outline drawings of SB100-0.4/0.55T4~SB100-3.7/5.5T4 models(can be DIN rail mounted):

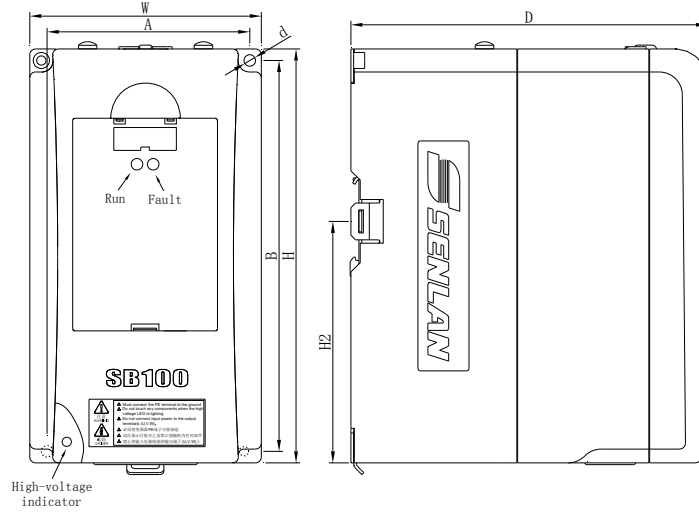

Outline drawings of SB100-5.5/7.5T4~SB100-18.5/22T4 models:

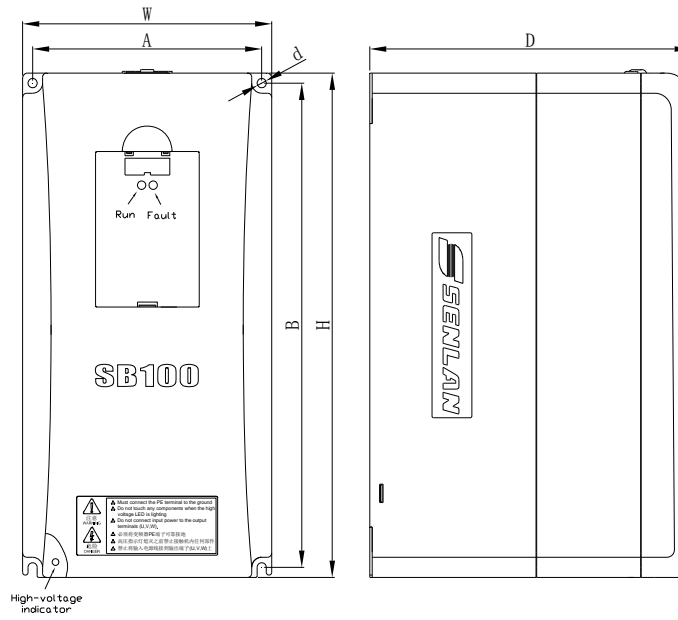

2 SPECIFICATIONS

Outline dimensions and weights of SB100 inverters:

Inverter model	W (mm)	H (mm)	H2 (mm)	D (mm)	A (mm)	B (mm)	d (mm)	Weight (kg)
SB100-0.4/0.55T4	100	180	105	157	87.5	170	Φ4.5	2
SB100-0.75/1.1T4								
SB100-1.5/2.2T4								
SB100-3/4T4	135	240	140	170	125	230	Φ4.5	3
SB100-3.7/5.5T4								
SB100-5.5/7.5T4	150	300	—	195	138	288	Φ5.5	7
SB100-7.5/11T4								
SB100-11/15T4	200	380	—	225	185	367	Φ7	10
SB100-15/18.5T4								
SB100-18.5/22T4								

3 Installation and Wiring

3.1 Installation of inverter

 DANGER	<ol style="list-style-type: none"> 1. The installation of the inverter can be performed only by qualified professionals. 2. Do not install and run the inverter if there is any damage on the inverter or any part is missing, otherwise there may be a risk of fire and injury. 3. Install the inverter on a firm support that can bear its weight, otherwise the inverter may fall and cause damage or injury. 4. Do not apply force on the keypad or cover board while handling the inverter, otherwise the falling of keypad or cover board may cause damage or injury.
--	---

In addition to meeting the environment requirements, the inverter should be installed vertically instead of upside down, slantways or horizontally, and fixed to a firm structure with screws. To ensure cooling effect, sufficient space should be maintained around the inverter, as shown below (a partition board should be provided in between if two inverters are installed in a vertical row).

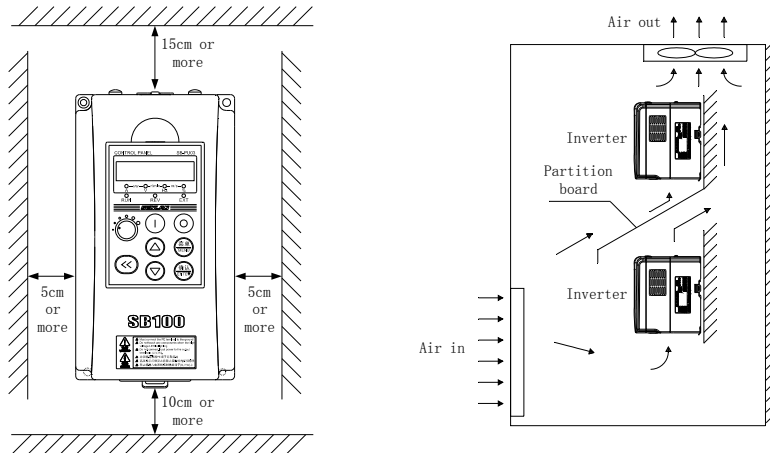

3.2 Installation and removal of parts

3.2.1 Installation (via mounting box) and removal of keypad

Installation: Push the keypad in with the slot on its bottom aligning with the stopper on the mounting box.

Removal: Press the spring piece on top of the keypad and pull out.

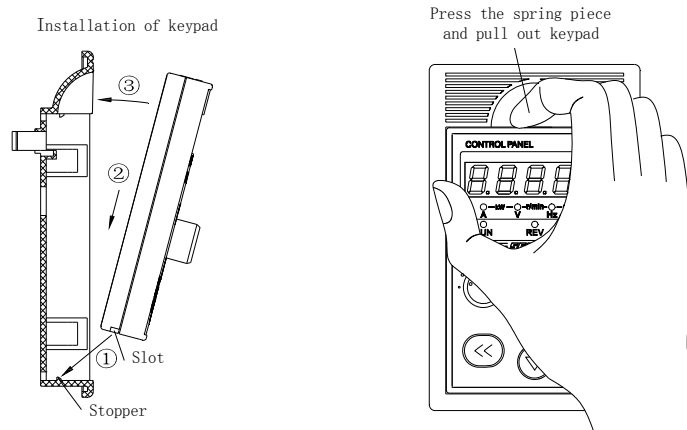

3.2.2 Installation of keypad on cabinet front cover

The keypad of the SB100 inverter can be installed onto the front cover of the cabinet, with the keypad and inverter connected by the extension cable. You can choose one of the following two installing methods.

◆ Method 1: Direct installatio

- Make an opening on the front cover of the cabinet according to the following diagram (a).
- Remove the two screws on the diagonal of the keypad, and fix the keypad to the front cover with the two M3×14 screws shipped with the product.
- Insert one end of the extension cable into the keypad and fix it with the fastener shipped with the product, and insert the other end of the extension cable into the corresponding connector on the inverter, as shown below in diagram (b).

◆ Method 2: Installation via the mounting box(option)

- Make an opening on the front cover of the cabinet according to the following diagram (c).
- Install the mounting box onto the front cover.
- Install the keypad into the mounting box.
- Insert one end of the extension calbe into the keypad and the other end into the corresponding connector on the inverter.

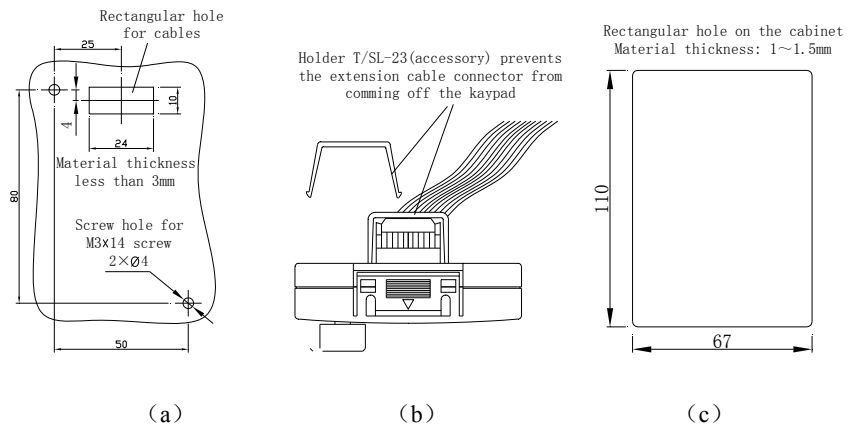

3.3 Peripherals and options

The connection between the inverter and its peripherals is shown as below:

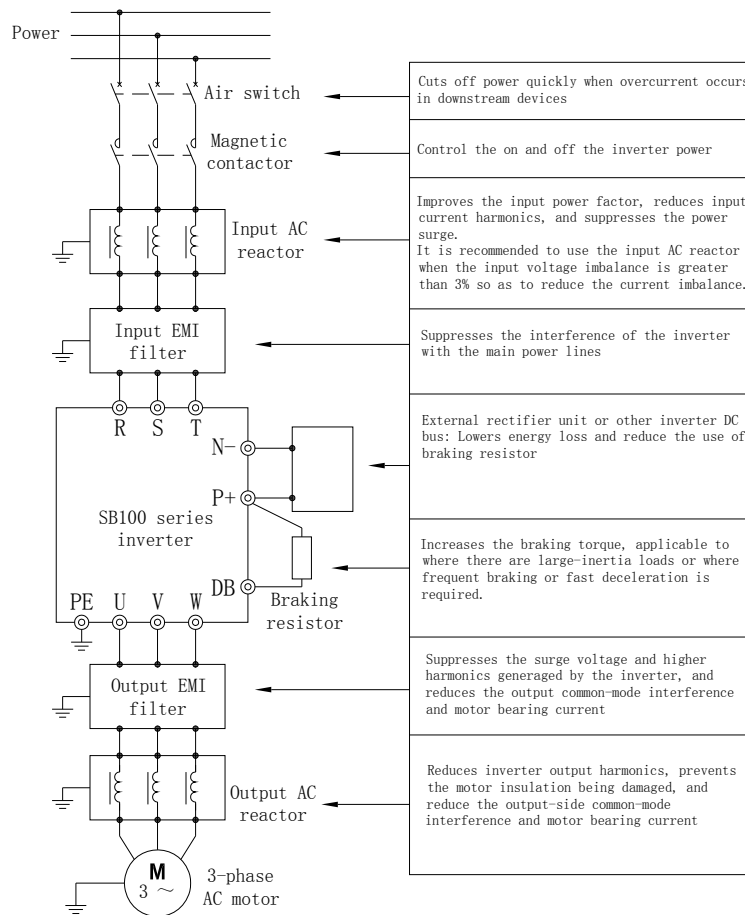

Options provided by our company include keypad with the direction key(SB-PU70), keypad mounting box, keypad extension cable, braking resistor, input/output reactor, EMI filter, monitoring software SENLANWin, Profibus-DP module, remote control box, etc..

The resistance and capacity of the braking resistor we recommend are listed in the following table.

Inverter model	Resistance Ω	Capacity reference value kW	Inverter model	Resistance Ω	Capacity reference value kW
SB100-0.4/0.55T4	≥ 500	≥ 0.14	SB100-5.5/7.5T4	≥ 90	≥ 1.80
SB100-0.75/1.1T4	≥ 300	≥ 0.40	SB100-7.5/11T4	≥ 65	≥ 2.50
SB100-1.5/2.2T4	≥ 150	≥ 0.55	SB100-11/15T4	≥ 65	≥ 4.00
SB100-3/4T4	≥ 130	≥ 0.90	SB100-15/18.5T4	≥ 32	≥ 4.00

SB100-3.7/5.5T4	≥100	≥1.30	SB100-18.5/22T4	≥22	≥5.00
-----------------	------	-------	-----------------	-----	-------

3.4 Wiring of inverter

 DANGER
<ol style="list-style-type: none"> 1. Wiring of the inverter can be performed only by qualified professionals. 2. Before opening the cover board of the inverter, cut the power supply and wait for at least five minutes after all indicators of the inverter go out. 3. The wiring inside the inverter can only begin after the internal high-voltage indicator of the inverter goes out or the voltage between terminals P+ and N-(measured with voltmeter) is less than 36V. 4. The inverter must be earthed reliably, otherwise there may be a risk of electric shock or fire. 5. Shorting P+ and N- is prohibited. That may cause fire or damage to properties. 6. Connecting the power line with U, V or W is prohibited. 7. Before turning on the power verify the rated input voltage of the inverter is consistent with the voltage of the AC power supply, otherwise injury to people or damage to equipment may occur. 8. All terminals must be securely connected. 9. The output terminals U, V and W must be connected in strict phase order. 10. Connecting surge absorbing capacitors or voltage-dependent resistors on the output side of the inverter is prohibited.

3.4.1 Terminal configuration before shipment from factory

The terminal configuration and the basic wiring for SB100 are as follows:

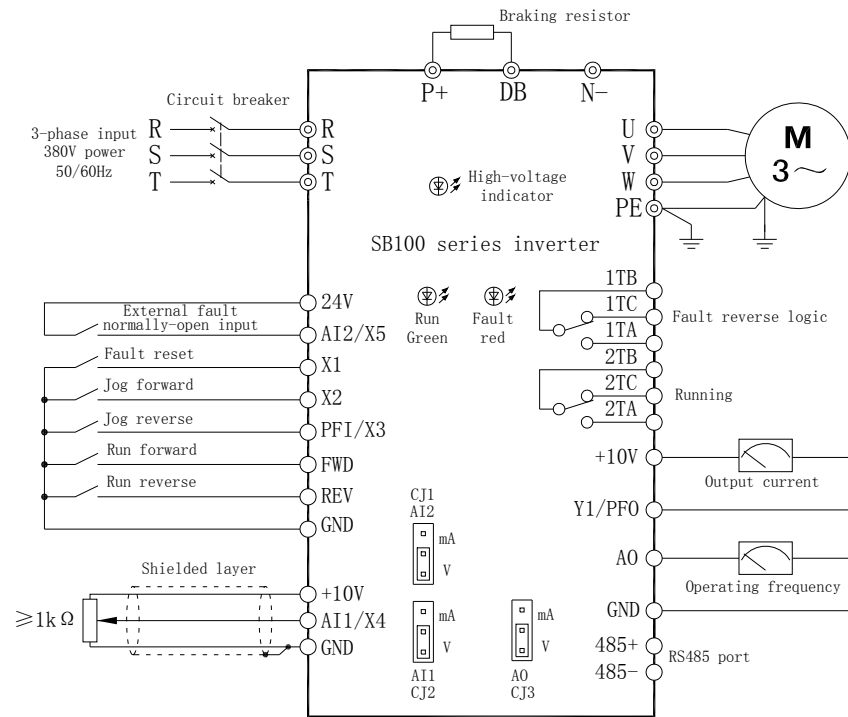

3.4.2 Main circuit terminals and wiring

Symbol	Name	Description
R, S, T	Input power terminal	To 3-phase 380V power supply
U, V, W	Inverter output terminal	To 3-phase motor
P+, N-	DC bus terminal	Used for common DC bus or for connecting an external rectifier unit. Consult the factory for the use of the common DC bus.
DB	Braking output terminal	Braking resistor is connected between P+ and DB
PE	Grounding terminal	Used for connecting inverter case to earth

Arrangements of main circuit terminals:

SB100-0.4/0.55T4~SB100-1.5/2.2T4: (PE is located at the bottom right corner of the bottom board)

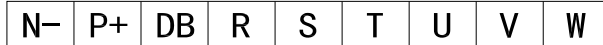

SB100-3/4T4~SB100-18.5/22T4:

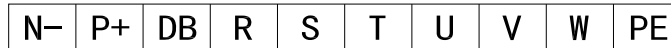

The air switch, the main circuit wiring and its stripping length are recommended as follows:

Inverter model	Air switch (A)	Main circuit wiring (mm ²)	Stripping length (mm)
SB100-0.4/0.55T4~SB100-1.5/2.2T4	16	2.5	6

SB100-3/4 T4~SB100-3.7/5.5T4	20	4	6
SB100-5.5/7.5 T4~SB100-7.5/11T4	40	6	10
SB100-11/15 T4~SB100-15/18.5T4	63	8	(Φ 5 cold-pressed terminal)
SB100-18.5/22T4	100	10	(Φ 5 cold-pressed terminal)

3.4.3 Control board terminals and wiring

Arrangements of control board terminals: (1mm² copper wires with a stripping length of 5mm is recommended as the wiring)

485+	Y1/PFO	X5/AI2	X4/AI1	X3/PFI	X2	X1	2TA	2TC	2TB
485-	AO	GND	+10V	24V	REV	FWD	1TA	1TC	1TB

Functions of control board terminals:

Symbol	Name	Function and description	Specification
485+	485 differential signal(positive end)	RS485 communication port	Connect up to 32 RS485 stations Input impedance>10k Ω
485-	485 differential signal(negative end)		
GND	Ground	—	—
+10V	+10V reference power supply	+10V power supplied to user	Max. output current is 10mA, with the voltage accuracy higher than 2%
Y1/PFO	Digital output/pulse frequency output	Digital output: Refer to F5 Pulse frequency output: Refer to F6-15	Open collector output 24V DC/50mA Conducting voltage<0.5V 0 ~ 50 kHz , open collector output, 24V/50mA
X1	X1 digital input terminal	Refer to F4	Input impedance \geq 3k Ω Input voltage<30V Sampling period: 1ms Anti-jittering time: 10ms High level>10V Low level<4V Equivalent to “high level” if not connected
X2	X2 digital input terminal		
REV	REV digital input terminal		
FWD	FWD digital input terminal		
X3/PFI	X3 digital input/pulse frequency input	Digital input: Anti-jittering time is 10ms Refer to F4 Pulse frequency input: 0~50kHz Refer to F6-12~F6-14	Sampling period: 1ms Input impedance: 1.5k Ω High level>6V Low level<3V Max. input voltage: 30V

3 INSTALLATION AND WIRING

X4/AI1	X4 digital input/ analog input 1	Digital input (refer to F4): Jumpers CJ2 and CJ1 are used to select the voltage type input(V).	Sampling period: 1ms Input impedance: 110kΩ for voltage input or 250Ω for current input Digital input: Anti-jittering time=10ms, input voltage<30V, high level>10V, low level<4V, and is equivalent to "low level" if not connected. Analog input: Input voltage is -10 ~ +10V, input current is -20 ~ +20mA
X5/AI2	X5 digital input/ analog input 2	Analog input(refer to F6-00 ~ F6-07): Jumpers CJ2 and CJ1 are used to select the voltage type(V) or current type input(mA)	
AO	Multi-function analog output	Refer to F6-08~F6-11. Jumper CJ3 selects the voltage type(V) or current type(mA) output	Current type: 0 ~ 20mA, load≤500Ω Voltage type: 0 ~ 10V, output≤10mA
24V	24V power supply	24V power supplied to user	Max. output current 80mA
1TA	Relay 1 output terminal	Refer to F5	TA-TB: Normally open TB-TC: Normally closed Contact: 250V AC/3A 24V DC/5A
1TB			
1TC			
2TA			
2TB			
2TC			

1) Wiring of analog input terminals

When analog signals are used for remote control, the control wires between the controller and inverter should be less than 30 meters in length. And since the analog signal is vulnerable to interference, the analog control wires should be laid apart from strong-electricity, relay or contactor circuit. The wiring should be shielded twisted pair cable and be as short as possible, with one of its end connected to the terminal GND of the inverter.

2) Wiring of multi-function digital output terminals(Y1) and relay output terminals(TA, TB, TC)

If an inductive load, such as electromagnetic relay, contactor and electromagnetic brake, is driven, a surge snubber circuit, voltage-dependent resistor or freewheeling diode(used in DC electromagnetic circuit. Be careful of the polarity during installation) should be installed. The elements of the snubber circuit should be installed near the sides of the winding of the relay or contactor, as shown below.

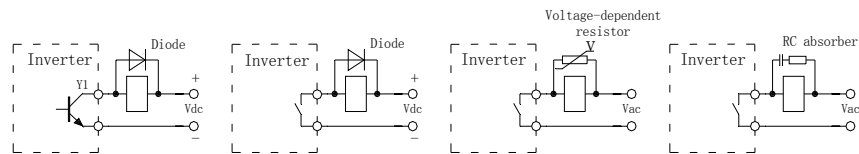

3.5 Methods of suppressing EMI

1. Countermeasures against EMI

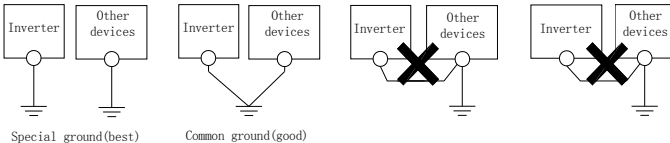
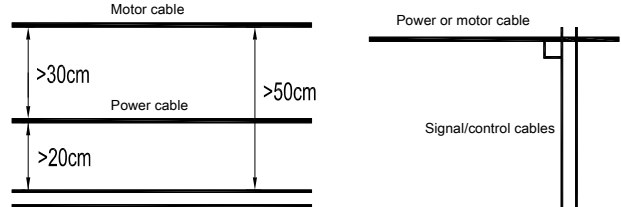
Interference source	Countermeasures
Leakage current Ground loop	<p>When peripheral devices form a closed circuit through the wiring of the inverter, the leakage current from the earthing line of the inverter will cause false action of devices. To reduce false action, you may leave devices unearthed. Grounding methods recommended and banned are listed below.</p>  <p style="text-align: center;">Special ground (best) Common ground (good)</p>
Power cable	<p>When peripheral devices share the same power supply with the inverter, the interference generated by the inverter will transmit along the power cable, causing false action of other devices in the same system. Following measures can be taken:</p> <ol style="list-style-type: none"> (1) Install an EMI filter or ferrite common-mode filter(magnetic ring) on the input side of the inverter. (2) Isolate noise of other devices with an isolation transformer or power supply filter.
Motor cable radiation Power cable radiation Inverter radiation	<p>As measuring meters, radios, sensors or signal lines are installed in the same cabinet with the inverter, they are easy to be interfered with and act falsely. Following measures can be taken:</p> <ol style="list-style-type: none"> (1) Install devices and signal lines which are easily affected as far as possible away from the inverter. The signal lines should be shielded wires and be earthed. They should be run in metal conduits, and be as far as possible away from the inverter and its input/output lines. If the signal lines have to cross the power cables, keep them at right angles, as shown below. 
	<ol style="list-style-type: none"> (2) Install an EMI filter or ferrite common-mode filter(magnetic ring) on both input and output side of the inverter. (3) Motor cable should be laid in a thick shield, such as conduits(over 2mm) or cement tubes. The power cable should be run in metal conduits and be shielded and earthed(the motor cable is a 4-core cable, one end of which is connected to earth one

	the inverter side, while the other end is connected to the motor case).
Static induction Electromagnetic induction	<p>(1) Avoid running signal lines in parallel with or in the same bundle with the power cables.</p> <p>(2) Try to keep devices and signal lines subject to disturbance as far as possible away from the inverter and its input and output lines.</p> <p>(3) Use shield wires as the signal lines and power cables and lay them in separate metal conduits, with the space between the two conduits being at least 20cm.</p>

2. Countermeasures against leakage current

Leakage current is generated due to the existence of capacitance between inverter input/output cables and earth, between lines and between the motor and earth. The size of the leakage current, including earth leakage current and inter-line leakage current, is determined by the size of the distributed capacitance and carrier frequency.

Sources of leakage current:

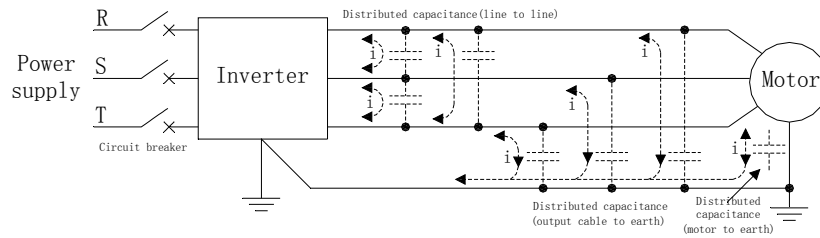

Earth leakage current

The leakage current may flow into not only the inverter system, but also other devices via the earth line, causing false action of the leakage circuit breaker, relay or other devices. The higher the carrier frequency and the longer the motor cables, the larger the leakage current.

Suppression measures: (1) Lower the carrier frequency, but that will increase the motor noise; (2) Minimize the length of the motor cables; (3) Use a leakage circuit breaker specially designed for higher harmonics and surge leakage current.

Inter-line leakage current

The higher harmonics of the leakage current from the inter-line distributed capacitance on the inverter output side may lead to false action of the external thermal relay, especially when the inverter has a small capacity and the wiring is very long(over 50m). Therefore we recommend you to use a temperature sensor to monitor the motor temperature directly or use the inverter's motor overload protection function to replace the external thermal relay.

Suppression measures: (1) Lower the carrier frequency; (2) Install a reactor on the output side.

4 Operation and Commissioning

4.1 Operation and display

4.1.1 Run indicator and fault indicator

The state of the inverter is indicated by the run indicator(green light) and fault indicator(red light). Green light ON indicates the inverter is running, green light blinking means the inverter is in standby state, and red light ON indicates a fault.

4.1.2 Functions of keypad

The keypad is used to set and browse parameters, control operations, display error information and so on. The layouts of the keypad of SB-PU03 and SB-PU70 are shown as below respectively:

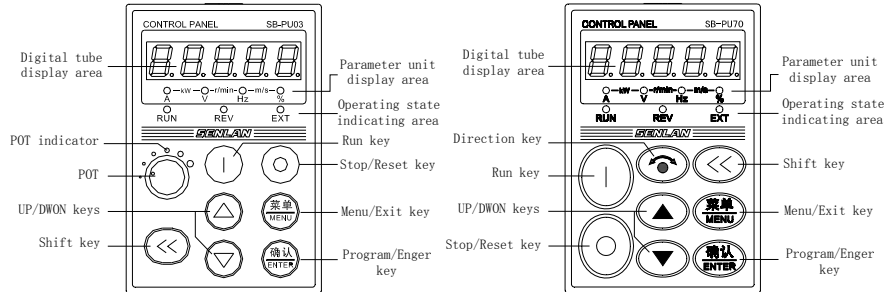

Discription of keys on the keypad:

Key	Name	Function
	Menu/Exit key	Return to previous menu; enter/exit monitoring state
	Program/Enter key	Enter next menu; save parameter; clear alarm information
	UP key	Increase/decrease number or data
	DOWN key	
	Shift key	Select digit to be modified; switch between monitored parameters
	Run key	Start inverter
	Stop/Reset key	Stop or fault reset
	Direction key	Change direction(only for keypad SB-PU70)

Meanings of unit indicators:

State of indicators	Unit	State of indicators	Unit
●-kW-○-r/min-○-m/s-○ A V Hz %	A	●-kW-●-r/min-○-m/s-○ A V Hz %	kW
○-kW-●-r/min-○-m/s-○ A V Hz %	V	○-kW-●-r/min-●-m/s-○ A V Hz %	r/min
○-kW-○-r/min-●-m/s-○ A V Hz %	Hz	○-kW-○-r/min-●-m/s-● A V Hz %	m/s
○-kW-○-r/min-○-m/s-● A V Hz %	%	○-kW-●-r/min-●-m/s-● A V Hz %	s or ms

Meanings of status indicators:

Indicator	Status	Inverter state
RUN indicator	Off	Standby state
	On	Stable run state
	Blinking	Accelerating or decelerating state
REV indicator	Off	Both preset and current direction are forward
	On	Both preset and current direction are reverse
	Blinking	Preset direction is inconsistent with current direction
EXT indicator	Off	Keypad control
	On	Terminal control
	Blinking	Communication control
POT(potentiometer) indicator	On	POT is selected as the source of main reference, auxiliary reference or PID reference(only for SB-PU03)

4.1.3 Display status and operation of keypad

The keypad of SB100 series inverter has the following display status: monitoring status(including in standby state and in run state), parameter editing status, fault display status, and alarm display status.

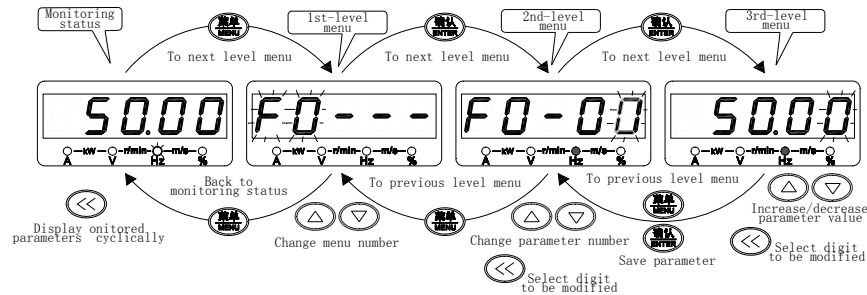







Monitoring status in standby state

Pressing \lll in this status cyclically displays the standby-state parameters(defined by FC-00~FC-03).







Monitoring status in run state

Pressing  in this status cyclically displays the run-state parameters(defined by FC-00~FC-08).

Parameter editing status

In monitoring status, pressing  enters the editing status, which contains three level menus: parameter group number→serial number in parameter group→parameter value. Pressing  enters the next menu and pressing  returns to the previous menu(returns to monitoring status if at the first level menu). Pressing  and  change the parameter group numbers, serial numbers in parameter group or parameter values. Under the third level menu, the digit which can be edited blinks. Pressing  switches the digit to be edited to another digit, and pressing  saves the modified data and returns to the second level menu, and the next parameter is displayed.

Password check status

If there is a user password(F0-12 not equal to zero), before you can edit any parameter you enter the password check status and “———” is displayed. Input the password with ,  and  (“———” is displayed during input) and press . If the password is not correct, “Err” blinks. At this moment, press  returning to the password check status and press  again exiting the password check status. If there is no any keystroke within ten seconds after the password protection has been removed, the password protection will take effect again automatically.

Fault display status

Once the inverter detects a fault signal, the keypad enters the fault display status, and the error code blinks.The fault can be reset by inputting reset command( key, control terminal or communication command). If the fault still exists, the error code continues to blink. During this period you can modify related parameters to eliminate the fault.

Alarm display status

When the inverter detects the alarm information, the alarm code blinks. If there are multiple alarm signals, the alarm codes display alternately. The alarm information can be temporarily hidden by pressing  or



. The alarm signal is automatically removed if normal state is recovered. The inverter does not stop in alarm display status.

4.2 Switching on the power for the first time

Connect the wires in accordance with the technical requirements specified in section 3.4.

After checking the wiring and power supply, close the air switch of the AC power on the inverter input side. “8.8.8.8” will first be displayed on the keypad of the inverter. When the contactor inside the inverter is closed normally, the display becomes the reference frequency. This shows the inverter initialization has been completed. If anything unusual occurs when the power is turned on, disconnect the air switch and check and remove the error.

4.3 Quick commissioning and optimization of commissioning

Quick commissioning:

1. Select frequency reference channel and set the reference frequency. Refer to F0-00 and F0-01.
2. Select command source. Refer to F0-02.
3. Set the max. frequency(F0-06), upper-limit frequency(F0-07), lower-limit frequency(F0-08) and max. output voltage(F2-10), and make sure $F0-06 \geq F0-07 > F0-08$.
4. Set the rotation direction of the motor. Refer to F0-05.
5. Set the accel/decel time: Set the time as long as possible, for too short accel/decel time may damage the load or lead to overcurrent. Refer to F1-00~F1-03.
6. Set the start and stop mode. Refer to F1-04 and F1-07.
7. Set the motor parameters, including rated capacity, pole number, rated current, rated frequency, rated speed and cooling condition. Refer to F3-00~F3-05.

Optimization of commissioning:

1. Manual torque boost level: If the current is overhigh at the start, reduce the value of this parameter. Refer to F2-00.
2. Auto torque boost: This function is recommended to raise the starting torque and the output torque at low speeds. Refer to F2-02.
3. Slip compensation: This function can reduce the speed drop caused by the load. It is only valid for auto torque boost. Refer to F2-03 and F2-04.
4. Vibration damping: If the motor vibrates, increase this parameter gradually until the vibration disappears. Refer to F2-06.

5 Parameter Table

Note: In the column “change” of the table below, “○” indicates the parameter is changeable in both running and standby states, “×” indicates unchangeable in running state, and “△” read only.

F0 Basic parameter

No.	Name	Setting range	Default	Change
F0-00	Digital reference frequency	0.00~650.00Hz	50.00Hz	○
F0-01	Main reference channel	0: F0-00 1: Communication 2: AI1 3: AI2 4: PFI(F4-02=0) 5: UP/DOWN value 6: Keypad POT	0	○
F0-02	Command source	1: Keypad 2: Terminal(○ invalid) 3: Terminal(○ valid) 4: Communication(○ invalid) 5: Communication(○ valid)	1	×
F0-03	Reference frequency hold mode	0: Saved upon power loss 1: Restored to F0-00 upon power loss 2: Restored to F0-00 upon power loss or stop Note: For reference frequency set by ▲ & ▼ or communication	0	○
F0-04	Auxiliary reference channel	1: Communication 2: AI1 3: AI2 4: PFI(F4-02=0) 5: UP/DOWN value 6: Keypad POT 7: None	7	○
F0-05	Direction lock	0: Forward or reverse 1: Forward only 2: Reverse only	0	○
F0-06	Max frequency	0.00~650.00Hz	50.00Hz	×
F0-07	Upper-limit frequency	0.00~650.00Hz	50.00Hz	×
F0-08	Lower-limit frequency	0.00~650.00Hz	0.00 Hz	×
F0-09	Rated capacity	Min unit: 0.01kW	-	△
F0-10	Software version	0.00~99.99	-	△
F0-11	Data initialization	11: Initialize 22: Clear fault history	00	×
F0-12	User password	0000~9999(0000 means no password)-+	0000	○

F1 Accel/decel, start, stop and jog parameters

No.	Name	Setting range	Default	change
F1-00	Accel time 1	0.1~3600.0s	6.0s	○
F1-01	Decel time 1			
F1-02	Accel time 2			
F1-03	Decel time 2			

5 PARAMETER TABLE

F1-04	Start mode	0: Start from starting frequency 1: Smooth start	0	×
F1-05	Starting frequency	0.00~60.00Hz	0.50Hz	○
F1-06	Starting frequency hold time	0.0~60.0s	0.0s	○
F1-07	Stop mode	0: Slowdown stop 1: Coast stop 2: Slowdown stop +DC braking	0	○
F1-08	DC braking frequency(for stop)	0.00~60.00Hz	0.50Hz	○
F1-09	DC braking waiting time	0.0~10.0s	0.0s	○
F1-10	DC braking/zero-speed delay time	0.0~60.0s	0.0s	○
F1-11	DC braking current(for stop)	0.0~100.0%(inverter rated current=100%)	50.0%	○
F1-12	Jog frequency	0.10~50.00Hz(acce/decel time 2 is adopted in jog run mode)	5.00Hz	○

F2 V/F Control parameters

No.	Name	Setting range	Default	Change
F2-00	Manual torque boost level	0.0~15.0%	-	○
F2-01	Manual torque boost cut-off point	0.00~650.00Hz	5.00Hz	○
F2-02	Auto torque boost level	0.0~100.0%	80.0%	×
F2-03	Slip compensation gain	0.0~300.0%	0.0%	○
F2-04	Slip compensation filtering time	0.1~25.0s	1.0s	×
F2-05	Torque boost select	0: No boost 1: Manual boost 2: Auto boost 3: Manual+auto boost	2	×
F2-06	Vibration damping	0~200	20	○
F2-07	AVR	0: Disabled 1: Enabled 2: Enabled except during decel	1	×
F2-08	V/F curve	0: Linear (1st power) 1: Reduced torque 1(1.2th power) 2: Reduced torque 2(1.5th power)	0	×
F2-09	Base frequency	1.00~650.00Hz	50.00Hz	×
F2-10	Max output voltage	150~500V	380V	×

F3 Motor parameters

No.	Name	Setting range	Default	Change
F3-00	Motor rated capacity	0.40~22.00kW	-	×
F3-01	Motor pole number	2~16	4	×
F3-02	Motor rated current	0.5~50.0A	-	×
F3-03	Motor rated frequency	20.00~650.00Hz	50.00Hz	×

F3-04	Motor rated speed	125~4000r/min	-	×
F3-05	Motor cooling condition	0: Common motor 1: Special motor for inverter	0	○
F3-06 ~ F3-09	Reserved	-	-	-

F4 Digital input terminals and multistep frequencies

No.	Name	Setting range	Default	Change
F4-00	X1 terminal	0: No signal ±1: Multistep frequency select 1 ±2: Multistep frequency select 2 ±3: Multistep frequency select 3	6	×
F4-01	X2 terminal	±4: Accel/decel time 2 select ±5: External fault input ±6: Fault reset	7	
F4-02	X3/PFI terminal	±7: Jog FWD ±8: Jog REV ±9: Coast stop/run disabled ±10: UP/DOWN increase	8	
F4-03	X4/AI1 terminal	±11: UP/DOWN decrease ±12: UP/DOWN clear ±13: Process PID disabled	0	
F4-04	X5/AI2 terminal	±14: 3-wire stop command ±15: Internal virtual FWD terminal ±16: Internal virtual REV terminal ±17: Accel/decel disabled	-5	
F4-05	FWD terminal	±18: Command source switched to terminal or keypad ±19: Reference frequency switched to AI1	15	
F4-06	REV terminal	±20: Multi-PID select 1 ±21: Multi-PID select 2 Note: Plus sign means low level is valid, while minus sign means high level is valid	16	
F4-07	FWD/REV mode	0: 1-wire(start/stop) 1: 2-wire 1(FWD, REV) 2: 2-wire 2(start/stop, direction) 3: 2-wire 3(Start, stop) 4: 3-wire 1(FWD, REV, stop) 5: 3-wire 2(run, direction, stop)	1	×
F4-08	UP/DOWN regulation mode	0: Level type(terminal) 1: Pulse type(terminal) 2: Level type(keypad) 3: Pulse type(keypad)	0	○
F4-09	UP/DOWN rate/step	0.01~100.00(unit: %/s or %)	1.00	○
F4-10	UP/DOWN memory select	0: Stored upon power loss 1: Cleared upon power loss 2: Cleared upon both stop and power loss	0	○
F4-11	UP/DOWN upper limit	0.0~100.0%	100.0%	○
F4-12	UP/DOWN lower limit	-100.0~0.0%	0.0%	○

5 PARAMETER TABLE

F4-13 ~ F4-19	Multistep frequency 1~7	0.00~650.00Hz The default values of multistep frequencies 1~7 are the serial numbers of these multistep frequencies respectively. Example: Multistep frequency 3 has a default value of 3.00Hz.0.00~650.00Hz	n.00Hz (n=1~7)	○
---------------------	-------------------------	---	-------------------	---

F5 Digital and relay outputs

No.	Name	Setting range	Default	Change
F5-00	Y1/PFO terminal	0: Ready for run ±1: Running ±2: Frequency reach ±3: Frequency reach detection signal ±4: Fault output ±5: Undervoltage lockout ±6: Fault auto-reset ±7: Restart after momentary power failure ±8: Alarm output ±9: Reverse running Note: 1. Minus sign means the output is reversed 2. Set F6-15=0 if Y1 is used.	0	×
F5-01	T1 relay output		-4	
F5-02	T2 relay output		1	
F5-03	T2 terminal closing delay	0.000~65.000s	0.000s	○
F5-04	T2 terminal closing delay		0.000s	
F5-05	Frequency reach detection band	0.00~650.00Hz	2.50Hz	○
F5-06	Frequency reach detection level	0.00~650.00Hz	50.00Hz	○
F5-07	Frequency reach detection hysteresis	0.00~650.00Hz	1.00Hz	○

F6 Analog and pulse frequency terminals

No.	Name	Setting range	Default	Change
F6-00	AI1 input	0: 0~10V or 0~20mA(corresponding to 0~100%) 1: 10~0V or 20~0mA(corresponding to 0~100%) 2: 2~10V or 4~20mA(corresponding to 0~100%) 3: 10~2V or 20~4mA(corresponding to 0~100%) 4: -10~10V or -20~20mA(corresponding to -100~100%) 5: 0~10V or 0~20mA(corresponding to -100~100%, with 5V or 10mA at the center)	0	○
F6-01	AI1 gain	-999.9~999.9%	100.0%	○
F6-02	AI1 bias	-99.99~99.99%(10V or 20mA=100%)	0.00%	○
F6-03	AI1 filtering time	0.000~10.000s	0.100s	○
F6-04	AI2 input	Same as F6-00	0	○
F6-05	AI2 gain	-999.9~999.9%	100.0%	○
F6-06	AI2 bias	-99.99~99.99%(10V or 20mA=100%)	0.00%	○
F6-07	AI2 filtering time	0.000~10.000s	0.100s	○

F6-08	AO function	1: Operating frequency 2: Reference frequency 3: Output current 4: Output voltage 5: Output capacity 6: PID feedback value 7: PID reference value 8: AI1 9: AI2 10: PFI(F4-02=0) 11: UP/DOWN value 12: DC bus voltage	1	○
F6-09	AO type	0: 0~10V or 0~20mA 1: 2~10V or 4~20mA 2: 5V or 10mA at the center	0	○
F6-10	AO gain	0.0~1000.0%	100.0%	○
F6-11	AO bias	-99.99~99.99%, 以10V或20mA为100%	0.00%	○
F6-12	PFI frequency corresponding to 100%	0~50000Hz	10000Hz	○
F6-13	PFI frequency corresponding to 0%	0~50000Hz	0Hz	○
F6-14	PFI filtering time	0.000~10.000s	0.100s	○
F6-15	PFO function	Same as F6-08(0 indicates Y1 terminal is valid)	3	○
F6-16	PFO output pulse modulation method	0: Frequency modulation 1: Duty-ratio modulation	1	○
F6-17	PFO frequency corresponding to 100%	0 ~ 50000Hz(also used as the duty-ratio modulation frequency)	10000Hz	○
F6-18	PFO frequency corresponding to 0%	0~50000Hz	0Hz	○
F6-19	PFO duty ratio corresponding to 100%	0.0~100.0%	100.0%	○
F6-20	PFO duty ratio corresponding to 0%	0.0~100.0%	0.0%	○

F7 Process PID parameters

No.	Name	Setting range	Default	Change
F7-00	PID control function	0: Disabled 1: Enabled 2: PID corrects the reference frequency	0	○
F7-01	PID reference channel select	0: F7-03 1: AI1 2: AI2 3: PFI(F4-02=0) 4: AI1-AI2 5: AI1+AI2 6: UP/DOWN value 7: Keypad POT 8: Communication	0	×
F7-02	PID feedback channel select	1: AI1 2: AI2 3: PFI(F4-02=0) 4: AI1-AI2 5: AI1+AI2 6: UP/DOWN value	1	×
F7-03	PID digital reference	-100.0~100.0%	0.0%	○

5 PARAMETER TABLE

F7-04	Proportional gain	-99.99~99.99	0.20	○
F7-05	Integral time	0.00~100.00s(0 indicates no integral)	20.00s	○
F7-06	Differential time	0.000~10.000s	0.000s	○
F7-07	Sampling period	0.001~10.000s	0.010s	○
F7-08	PID upper limit	-100.0~100.0%(Max frequency=100%)	100.0%	○
F7-09	PID lower limit	-100.0~100.0%(Max frequency=100%)	0.0%	○
F7-10	Multi-PID reference 1	-100.0~100.0%	1.0%	○
F7-11	Multi-PID reference 2		2.0%	
F7-12	Multi-PID reference 3		3.0%	

Fb Protection functions and advanced settings

No.	Name	Setting range	Default	Change
Fb-00	Motor overload protection level	50.0~150.0%(motor rated current=100%)	100.0%	○
Fb-01	Motor overload protection action	0: No action 1: Motor continues running with an alarm 2: Motor coasts to a stop due to the fault	2	×
Fb-02	Analog input drop protection	0: No action 1: Alarm AL.Aco is output 2: Motor runs at F0-00 with alarm AL.Aco 3: Motor coasts to a stop due to fault Er.ACo	0	×
Fb-03	Phase loss protection	0: No action 1: Motor coasts to a stop with alarm Er.PLI(input phase loss) 2: Motor coasts to a stop with alarm Er.Plo(output phase loss) 3: Motor coasts to a stop(input & output phase loss)	3	×
Fb-04	Overcurrent stall level	0.0~150.0%(0.0 means invalid. Inverter rated current=100%)	110.0%	×
Fb-05	Overvoltage stall level	0~750V(0 means invalid)	700V	×
Fb-06	DC bus undervoltage protection	0: Motor coasts to a stop due to fault Er.dCL 1: Motor coasts to a stop and restarts after power resumes	0	×
Fb-07	DC bus underfoltage level	370~480V	400V	×
Fb-08	Fault auto-reset times	0~10	0	×
Fb-09	Fault auto-reset interval	1.0~30.0s	5.0s	×
Fb-10	Fault output during auto-reset	0: Not output 1: Output	0	×
Fb-11	Power-on auto start	0: Disabled 1: Enabled	1	○
Fb-12	Built-in braking unit working point	620~720V	680V	○
Fb-13	Carrier frequency	1.1k~16.0kHz Note: The factory settings are 2.5kHz for SB100-7.5/11T4, 3.5kHz for SB100-15/18.5T4,	-	○

No.	Name	Setting range	Default	Change
		3.0kHz for SB100-18.5/22T4, and 4.0kHz for other models.		
Fb-14	Carrier frequency auto regulation	0: Disabled 1: Enabled	1	○
Fb-15	Cooling fan control	0: Cooling fan stops after standby state lasts 3 minutes 1: Cooling fan keeps running	0	○
Fb-16	Jump frequency	0.00~625.00Hz	0.00Hz	○
Fb-17	Jumping width	0.00~20.00Hz	0.00Hz	○

FC Keypad operation and display settings

No.	Name	Setting range	Default	Change
FC-00	Monitored parameter 1(run & stop)	0~21	1	○
FC-01	Monitored parameter 2(run & stop)	-1~21	-1	○
FC-02	Monitored parameter 3(run & stop)		-1	○
FC-03	Monitored parameter 4(run & stop)		-1	○
FC-04	Monitored parameter 1(run)	-1~21	0	○
FC-05	Monitored parameter 2(run)		2	○
FC-06	Monitored parameter 3(run)		4	○
FC-07	Speed display coefficient		0.001~10.000	1.000
FC-08	Line speed display coefficient	0.01~100.00	0.01	○

FF Communication parameters

No.	Name	Setting range	Default	Change
FF-00	Communication data format	0: 8,N,1 1: 8,E,1 2: 8,O,1 3: 8,N,2	0	×
FF-01	Baud rate	0: 1200bps 1: 2400bps 2: 4800bps 3: 9600bps 4: 19200bps 5: 38400bps	3	×
FF-02	Local address	1~247	1	×
FF-03	Communication overtime detection time	0.1~600.0s	10.0s	○
FF-04	Communication overtime action	0: No action 1: Alarm 2: Motor runs at F0-00 with alarm 3: Motor coasts to a stop due to fault	0	×

5 PARAMETER TABLE

Fn Factory parameters





FP Fault history

No.	Name	Description
FP-00	Last fault	0: No fault 1: ocb(instantaneous overcurrent at start) 2: ocA(overcurrent in accel) 3: ocd(overcurrent in decel) 4: ocn(overcurrent in constant-speed run) 5: ouA(overvoltage in accel) 6: oud(overvoltage in decel) 7: oun(overvoltage in constant-speed run) 8: ouE(overvoltage in standby) 9: dcl(undervoltage in running) 10: PLI(input phase loss) 11: Plo(output phase loss) 12: FoP(power device protection) 13: oHI(inverter overheating) 14: oLI(inverter overload) 15: oLL(motor overload) 16: EEF(external fault) 17: CFE(communication overtime) 18: ccF(current check fault) 19: Aco(analog input drop) 20: rHo(thermal resistor open) 21: Io1(reserved) 22: Io2(reserved)
FP-01	2nd last fault	Same as FP-00
FP-02	3rd last fault	Same as FP-00
FP-03	Operating frequency at last fault	Min unit: 0.01Hz
FP-04	Reference frequency at last fault	Min unit: 0.01Hz
FP-05	Output current at last fault	Min unit: 0.1A
FP-06	DC bus voltage at last fault	Min unit: 0.1V
FP-07	Heat-sink temperature at last fault	Min unit: 0.1°C

FU Data monitoring

No.	Name	Description
FU-00	Operating frequency	Min unit: 0.01Hz
FU-01	Reference frequency	Unit indicator blinks. Min unit: 0.01Hz
FU-02	Output current	Min unit: 0.1A
FU-03	Load current percentage	Inverter rated current=100%. Min unit: 0.1%
FU-04	Output voltage	Min unit: 0.1V
FU-05	Operating speed	Min unit: 1r/min
FU-06	Reference speed	Unit indicator blinks. Min unit: 1r/min
FU-07	DC bus voltage	Min unit: 0.1V
FU-08	Output capacity	Min unit: 0.1kW
FU-09	Operating line speed	Min unit: 1m/s
FU-10	Reference line speed	Unit indicator blinks. Min unit: 1m/s
FU-11	PID feedback	Min unit: 0.1%
FU-12	PID reference	Unit indicator blinks. Min unit: 0.1%
FU-13	AI1	Min unit: 0.1%
FU-14	AI2	Min unit: 0.1%
FU-15	PFI	Min unit: 0.1%
FU-16	UP/DOWN value	Unit indicator blinks. Min unit: 0.1%
FU-17	Digital input terminal status	Binary code is displayed in decimal format. From highest bit to lowest one: REV, FWD, X5, X4, X3, X2, X1

5 PARAMETER TABLE

FU-18	Digital output terminal status	Binary code is displayed in decimal format. From highest bit to lowest one: T2, T1, Y1
FU-19	Heat-sink temperature	Min unit: 0.1°C
FU-20	Output frequency	Used by factory. Min unit: 0.01Hz
FU-21	Max current hold	Cleared by pressing  or  . Min unit: 0.1A
FU-22	Max DC bus voltage hold	Cleared by pressing  or  . Min unit: 1V
FU-23 ~ FU-26	Reserved	—

6 Parameter Description

6.1 F0 Basic parameters

F0-00	Digital reference frequency	Default	50.00Hz	Change	○
Setting range	0.00~650.00Hz				
F0-01	Main reference channel	Default	0	Change	○
Setting range	0: F0-00(adjusted by ▲ & ▼) 2: AI1 3: AI2 4: PFI(F4-02=0) 1: Communication(F0-00 as initial value) 5: UP/DOWN value 6: Keypad POT				

The reference frequency sources are shown in the diagram below.

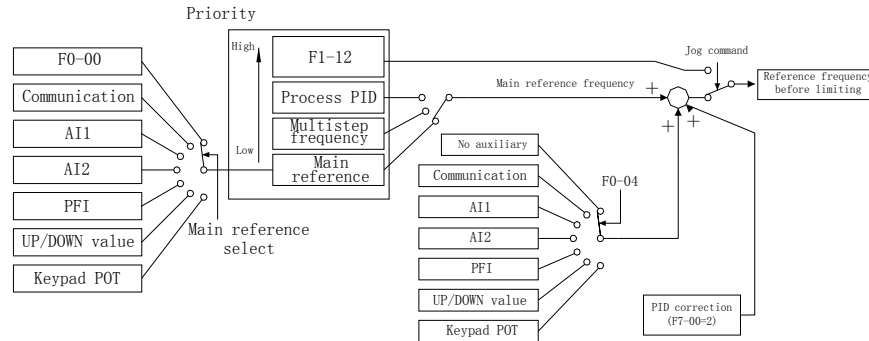

- 📖 The inverter has four operating modes, with their priority order being Jog>Process PID>Multistep frequency>Common operation. Example: If the function of multistep frequency is valid in common operation, the multistep frequency will be the main reference frequency.
- 📖 Main reference for common operation is selected by F0-01, and can be switched forcibly to AI1 by “digital input 19”(refer to the Table of Digital Input Functions described in Section 6.5)
- 📖 Under the terminal or communication control, jog run can be achieved by digital inputs 7 and 8.
- 📖 The reference frequency finally used is limited by F0-07 and F0-08.

F0-02	Command source	Default	1	Change	×
Setting range	1: Keypad(lamp EXT off) 2: Terminal(⊖ invalid, EXT on) 3: Terminal(⊕ valid, EXT on) 4: Communication(⊖ invalid, EXT blinking) 5: Communication(⊕ valid, EXT blinking)				

- 📖 When keypad is selected as the command source, the key ⊕ on the keypad can change the run direction(default direction is forward).
- 📖 Digital input 18 can switch the command source forcibly to terminal or keypad.

F0-03	Reference frequency hold mode	Default	0	Change	○
--------------	--------------------------------------	---------	---	--------	---

Setting range	0: Main reference frequency modified by ▲, ▼ or communication is saved into F0-00 upon power loss 1: Main reference frequency modified by ▲, ▼ or communication is restored to F0-00 upon power loss 2: Main reference frequency modified by ▲, ▼ or communication is restored to F0-00 upon power loss or stop
---------------	---

☞ This parameter is valid only when F0-01=0 or 1.

F0-04	Auxiliary reference channel	Default	7	Change	○
Setting range	1: Communication 2: AI1 3: AI2 4: PFI(F4-02=0) 5: UP/DOWN value 6: Keypad POT 7: None				

☞ Refer to F0-00 and F0-01.

F0-05	Direction lock	Default	0	Change	○
Setting range	0: Forward or reverse 1: Forward only 2: Reverse only				

☞ It is recommended to lock the direction only when a single direction is needed.

F0-06	Max frequency	Default	50.00Hz	Change	×
F0-07	Upper-limit frequency	Default	50.00Hz	Change	×
F0-08	Lower-limit frequency	Default	0.00Hz	Change	×
Setting range	0.00~650.00Hz				

☞ Make sure $F0-06 \geq F0-07 > F0-08$.

F0-09	Rated capacity	Default	-	Change	△
--------------	-----------------------	---------	---	--------	---

☞ Minimum unit: 0.01kW.

F0-10	Software version	Default	-	Change	△
--------------	-------------------------	---------	---	--------	---

☞ The range is between 0.00 and 99.99.

F0-11	Data initialization	Default	00	Change	×
Setting range	11: Initialize 22: Clear fault history Note: F0-11 turns to 00 after initialization is finished				

☞ Initialization restores parameters to their factory settings without clearing the fault history.

F0-12	User password	Default	0000	Change	○
Setting range	0000~9999(0000 means no password) Note: After password is set, it will take effect if there is no key pressing within ten seconds				

6.2 F1 Accel/decel, start, stop and jog parameters

F1-00	Accel time 1	Default	6.0s	Change	○
F1-01	Decel time 1	Default	6.0s	Change	○
F1-02	Accel time 2	Default	6.0s	Change	○
F1-03	Decel time 2	Default	6.0s	Change	○
Setting range	0.1~3600.0s				

☞ F1-00~F1-03 provide two sets of accel/decel time. Digital input 4 can be used to select the 2nd set of

accel/decel time, i.e. accel/decel time 2.

 Accel(decel) time is the time period over which the frequency increases(decreases) by 50Hz.

 Accel and decel time 2 are also used as the accel and decel time for jog run respectively.

F1-04	Start mode	Default	0	Change	×
Setting range	0: Start from starting frequency 1: Smooth start				
F1-05	Starting frequency	Default	0.50Hz	Change	○
Setting range	0.00~60.00Hz				
F1-06	Starting frequency hold time	Default	0.0s	Change	○
Setting range	0.0~60.0s				

 F1-04=0: The motor starts from the starting frequency(F1-05) and keeps running at this frequency for a period of time(F-06), and then accelerates. This helps reduce the current impact at the start.

F1-04=1: The motor starts smoothly from the frequency at which the motor runs just before its last stop. This helps shorten the starting process and reduce the starting impact.

 Smooth start(F1-04=1) can be used for restart after momentary stop or restart after fault auto-reset.

 **CAUTION: Smooth start is recommended for the start of high-speed or large-inertia loads.**

 **CAUTION: Starting from the starting frequency immediately after the coast stop will lead to overcurrent due to the existence of back electromotive force. Therefore, if an immediate start is required after the coast stop but the motor still keeps turning, we recommend you to adopt the smooth start.**

F1-07	Stop mode	Default	0	Change	○
Setting range	0: Slowdown stop 1: Coast stop 2: Slowdown stop +DC braking				
F1-08	DC braking frequency(for stop)	Default	0.50Hz	Change	○
Setting range	0.00~60.00Hz				
F1-09	DC braking waiting time	Default	0.0s	Change	○
Setting range	0.0~10.0s				
F1-10	DC braking/zero-speed delay time	Default	0.0s	Change	○
Setting range	0.0~60.0s				
F1-11	DC braking current(for stop)	Default	50.0%	Change	○
Setting range	0.0~100.0%(inverter rated current=100%)				

 F1-07=0: The inverter slows down, and then enters the standby state when its frequency drops to F1-08 or enters the zero-speed delay state if F1-10≠0.

F1-07=1: The inverter blocks its output and the motor coasts to a stop. Notice that the stop mode for jog run is always slowdown stop. It is not recommended to adopt coast stop for water pumps, for a water pump has a shorter stop time and its sudden stop will produce the “water hammer”.

F1-07=2: The inverter slows down, blocks its output when its frequency drops to F1-08, after a period of

time(F1-09), injects the DC braking current(F1-11) into the motor, and then stops following another period of time(F1-10).

⚠ CAUTION: DC braking is only recommended for low speeds(less than 10Hz) or smaller motors.

⚠ CAUTION: As DC braking consumes the mechanical energy of the load in the motor rotor, long-time or frequent DC braking will easily cause overheating of the motor.

📖 Zero-speed delay: Under the slowdown stop mode(F1-07=0), when the frequency drops to F1-08, the motor continues decelerating to zero within the time set by F1-10 and keeps running at zero frequency. By dosing so, the motor keeps being excited so that it can be started quickly at any moment. The process of zero-speed delay is shown as below.

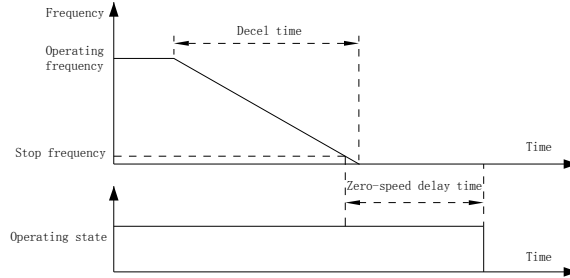

F1-12	Jog frequency	Default	5.00Hz	Change	○
Setting range	0.10~50.00Hz				

📖 Digital input 7 or 8 is used to activate jog run. Jog is invalid if both inputs are valid or invalid. Jog is only valid for terminal control or communication control.

📖 Under jog run mode, auxiliary reference and PID frequency correction are invalid.

📖 The jog start/stop mode is: start from starting frequency+slowdown stop+accel/decel time 2.

6.3 F2 V/F control parameters

F2-00	Manual torque boost level	Default	-	Change	○
Setting range	0.0~15.0%(F2-10=100%)				
F2-01	Manual torque boost cut-off point	Default	5.00Hz	Change	○
Setting range	0.00~650.00Hz				
F2-02	Auto torque boost level	Default	80.0%	Change	×
Setting range	0.0~100.0%				

📖 Manual torque boost is valid when F2-05=1 or 3, while auto torque boost is valid when F2-05=2 or 3.

📖 Manual torque boost can increase the motor's torque at low speeds or at the start, however, excessive boost will lead to motor overheating or overcurrent.

📖 The V/F curve is as follows.

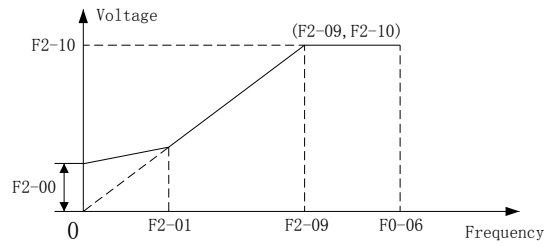

Auto torque boost changes the voltage according to the load current automatically, ensuring a high output torque under a heavy load and a low output current under no-load.

F2-03	Slip compensation gain	Default	0.0%	Change	○
Setting range	0.0~300.0%				
F2-04	Slip compensation filtering time	Default	1.0s	Change	×
Setting range	0.1~25.0s				

Slip compensation is valid only when F2-05=2 or 3.

Slip compensation regulates the inverter output frequency according to the load torque, thus reducing the speed change with the load and improving the speed control accuracy.

The amount of slip compensation is adjusted by F2-03. 100% of F2-03 indicates the compensation value under the rated torque equals the rated slip frequency, which is calculated based on the following formula:
 rated slip frequency=(rated speed×pole number÷120)

If slip compensation causes the vibration of the motor, moderately increasing F2-04 can be considered.

F2-05	Torque boost select	Default	2	Change	×
Setting range	0: No boost 1: Manual boost 2: Auto boost 3: Manual+auto boost				

Refer to F2-00~F2-02.

F2-06	Vibration damping	Default	20	Change	○
Setting range	0~200				

This parameter suppresses the vibration of the motor under no-load or slight loads. The method is raising F2-06 gradually until the vibration is eliminated.

F2-07	AVR	Default	1	Change	×
Setting range	0: Disabled 1: Enabled 2: Enabled except during decel				

AVR means automatic voltage regulation. When the input voltage or DC bus voltage changes, the AVR function can keep the output voltage constant, which helps stabilize the manufacturing process and the product quality.

When the input voltage is higher than the rated voltage, AVR should be enabled to prevent the motor running under a very high voltage.

Setting F2-07=2 allows a quicker deceleration but generates a bit higher current.

CAUTION: If the load has a very large moment of inertia, F2-07 should be set to 2 to prevent the motor overheating during deceleration.

F2-08	V/F curve	Default	0	Change	×
Setting range	0: Linear (1st power) 1: Reduced torque 1(1.2th power) 2: Reduced torque 2(1.5th power)				

Reduced torque V/F curve can improve the efficiency of the motors for reduced torque loads(e.g. fans and pumps) when they are running under slight loads.

Besides improving the motor efficiency, the reduced torque V/F curve can lower the noise.

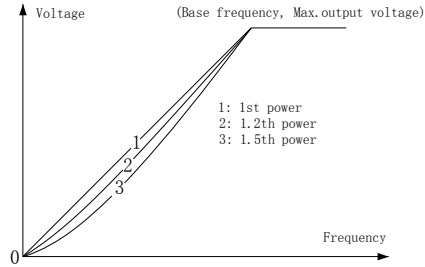

F2-09	Base frequency	Default	50.00Hz	Change	×
Setting range	1.00~650.00Hz				
F2-10	Max output voltage	Default	380V	Change	×
Setting range	150~500V				

Refer to F2-00~F2-02.

6.4 F3 Motor parameters

F3-00	Motor rated capacity	Default	-	Change	×
Setting range	0.40~22.00kW				
F3-01	Motor pole number	Default	4	Change	×
Setting range	2~16				
F3-02	Motor rated current	Default	-	Change	×
Setting range	0.5~50.0A				
F3-03	Motor rated frequency	Default	50.00Hz	Change	×
Setting range	20.00~650.00Hz				
F3-04	Motor rated speed	Default	-	Change	×
Setting range	125~40000r/min				

inverter causes the inverter to stop. External fault must be reset manually.

6: Fault reset. The rising edge of this signal resets the fault.

7~8: Jog FWD & REV. Refer to F1-12.

9: Coast stop/run disabled. If this signal is valid, the inverter is prohibited running or the motor coasts to a stop.

10~12: UP/DOWN increase & decrease. Refer to F4-08~F4-12.

13: Process PID disabled. If this signal is valid, PID is prohibited running. PID is allowed only when this signal is invalid and each operation mode that has a priority higher than PID is disabled(see F0-01 for operation priority).

14~16: 3-wire stop command, internal virtual FEW & REV terminals. Refer to F4-07.

17: Accel/decel disabled. The accel/decel process stops if this signal is in valid and resumes if it is invalid.

18: Command source switched to terminal or keypad. This signal, along with F0-02, can switch the command source from one to another, as shown in the following table.

F0-02 setting	Status of digital input 18	Command source selected
1: Keypad	Invalid	Keypad
	Valid	Terminal
2~3: Terminal	Invalid	Terminal
	Valid	Keypad
4~5: Communication	Invalid	Communication
	Valid	Keypad

19: Reference frequency switched to AI1. If this signal is valid, the reference frequency(for common operation) source will be forcibly switched to AI1.

20~21: Multi-PID selects 1~2. The combinations of these two signals determine which PID references are selected, as shown in the table below.

Multi-PID select 2	Multi-PID select 1	PID reference selected
0	0	Selected by F7-01
0	1	F7-10(multi-PID reference 1)
1	0	F7-11(multi-PID reference 2)
1	1	F7-12(multi-PID reference 3)

F4-07	FWD/REV mode	Default	1	Change	×
Setting range	0: 1-wire(start/stop)	1: 2-wire 1(FWD, REV)			
	2: 2-wire 2(star/stop, direction)	3: 2-wire 3(Start, stop)			
	4: 3-wire 1(FWD, REV, stop)	5: 3-wire 2(run, direction, stop)			

 Related digital inputs include 14(3-wire stop command), 15(internal virtual FWD terminal) and 16(internal virtual REV terminal)..

Each FWD/REV mode is illustrated in the following table, where S means “level valid” , while B means “edge valid” .

F4-07	FWD/REV mode	Logic			Diagram
0	1-wire(start/stop)	S: Run switch Note: Run direction depends on the direction of reference frequency.			
1	2-wire 1 (FWD, REV)	S2(REV)	S1(FWD)	Result	
		Invalid	Invalid	Stop	
		Invalid	Valid	FWD	
		Valid	Invalid	REV	
2	2-wire 2 star/stop, direction	S2 (direction)	S1 (start/stop)	Result	
		Invalid	Invalid	Stop	
		Invalid	Valid	FWD	
		Valid	Invalid	Stop	
3	2-wire 3 (Start, stop)	B1: Run button(normally open) B2: Stop button(normally closed) Note: Run direction depends on the direction of reference frequency.			
		B1: Stop button(normally closed) B2: FWD button(normally open) B3: REV button(normally open)			
		B1: Stop button(normally closed) B2: Run button(normally open) S: Direction switch(reverse when valid)			
		B1: Stop button(normally closed) B2: Run button(normally open) S: Direction switch(reverse when valid)			
4	3-wire 1 (FWD, REV, stop) Used with digital input 14	B1: Stop button(normally closed) B2: FWD button(normally open) B3: REV button(normally open)			
5	3-wire 2 (run, direction, stop) Used with digital input 14	B1: Stop button(normally closed) B2: Run button(normally open) S: Direction switch(reverse when valid)			

In the 1-wire/2-wire 1 or 2 mode under terminal control, if the motor is stopped by a stop command that comes from a source other than the terminal, then the stop command must be given before the run command to restart the inverter.

For modes of 2-wire 3 and 3-wire, the run button is invalid if the normally-closed stop button is open.

The run direction is limited by F0-05(direction lock) in any circumstance.

If the terminal command contains no direction information, the run direction will depend on the direction of the reference frequency source.

⚠ DANGER : If the run signal remains valid and Fb-11=1(default setting), the inverter will start automatically upon power on.

F4-08	UP/DOWN regulation mode	Default	0	Change	○
Setting range	0: Level type(terminal) 1: Pulse type(terminal) 2: Level type(keypad) 3: Pulse type(keypad)				
F4-09	UP/DOWN rate/setp	Default	1.00	Change	○
Setting range	0.01~100.00. Minimum unit: 0.01%/s(level type) or 0.01%(pulse type)				
F4-10	UP/DOWN memory select	Default	0	Change	○
Setting range	0: Stored upon power loss 1: Cleared upon power loss 2: Cleared upon both stop and power loss				
F4-11	UP/DOWN upper limit	Default	100.0%	Change	○
Setting range	0.0~100.0%				
F4-12	UP/DOWN Lower limit	Default	0.0%	Change	○
Setting range	-100.0~0.0%				

UP/DOWN function achieves continuous regulation by means of switch. The regulation value can be used as the frequency reference, PID reference, etc.

When F4-08=0, if digital input 10 or 11 is valid, FU-16 will increase or decrease at the rate set by F4-09; if digital input 10 and 11 are valid or invalid simultaneously, FU-16 remains unchanged.

When F4-08=1, each time a valid pulse of digital input 10 or 11 comes, FU-16 will increase or decrease a step set by F4-09.

Cases of F4-08=2 and 3 are similar to that of F4-08=0 and 1 respectively, except that digital inputs 10 and 11 are replaced by keypad keys \blacktriangle and \blacktriangledown .

The two UP/DOWN regulation modes are shown as the following diagrams.

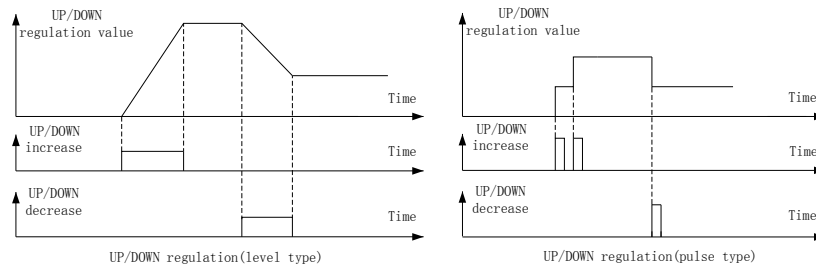

The rising edge of digital input 12 signal clears the value of FU-16.

F4-13 ~ F4-19	Multistep frequency 1~7	Default	n.00Hz (n=1~7)	Change	○
Setting range	0.00~650.00Hz The default values of multistep frequencies 1~7 are the serial numbers of these multistep frequencies respectively. Example: Multistep frequency 3 has a default value of 3.00Hz.				

6.6 F5 Digital and relay outputs

F5-00	Y1/PFO terminal	Default	0	Change	×
--------------	------------------------	---------	---	--------	---

6 FUNCTION DETAILS

F5-01	T1 relay output	Default	-4	Change	×
F5-02	T2 relay output	Default	1	Change	×
Setting range	0: Ready for run ±1: Running ±2: Frequency reach ±3: Frequency reach detection signal ±4: Fault output ±5: Undervoltage lockout ±6: Fault auto-reset ±7: Restart after momentary power failure ±8: Alarm output ±9: Reverse running Note: 1. Minus sign means the output is reversed 2. Set F6-15=0 if Y1 is used.				

📖 Related monitored parameters: FU-18.

📖 Description of digital output functions:

0: Ready for run. Inverter is ready to run.

1: Running. Inverter is in operation.

2: Frequency reach. This signal is valid if the inverter operating frequency falls in the range between the reference frequency minus F5-05 and the reference frequency plus F5-05.

3: Frequency reach detection signal. Refer to F5-06~F5-07.

4: Fault output. This signal is valid if the inverter is in fault status.

5: Undervoltage lockout. This signal is valid if DC bus undervoltage causes the inverter to stop.

6: Fault auto-reset. This signal is valid if fault auto-reset is in process.

7: Restart after momentary power failure. This signal is valid if the inverter is waiting for a restart after main circuit undervoltage occurs.

8: Alarm output. This signal is valid if the inverter gives an alarm.

9: Reverse running. This signal is valid if the inverter is running reverse.

Attention: Y1/PFO terminal is valid only when F6-15=0.

📖 Y1/PFO terminal is an open collector output. If its setting is a plus value, it is valid when it is closed; if its setting is a minus value, it is valid when it is open.

F5-03	T2 terminal closing delay	Default	0.000s	Change	○
F5-04	T2 terminal opening delay	Default	0.000s	Change	○
Setting range	0.000~65.000s				

📖 The digital output delay is shown as below.

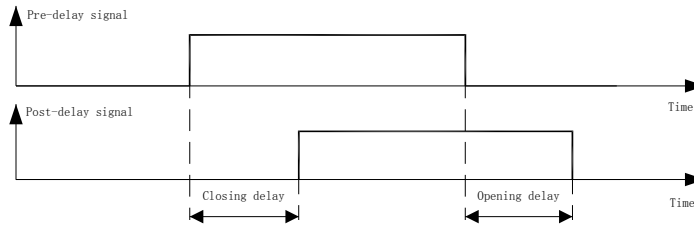

F5-05	Frequency reach detection band	Default	2.50Hz	Change	○
Setting range	0.00~650.00Hz				

The frequency reach signal is output when the inverter operating frequency is in the range between reference frequency minus F5-05 and reference frequency plus F5-05, as shown below.

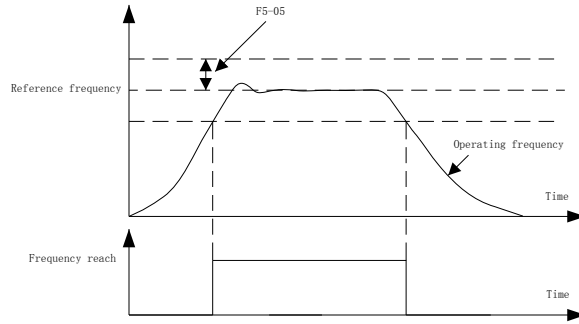

F5-06	Frequency reach detection level	Default	50.00Hz	Change	○
F5-07	Frequency reach detection hysteresis	Default	1.00Hz	Change	○
Setting	0.00~650.00Hz				

The digital output “frequency reach detection signal” becomes valid when the operating frequency is greater than F5-06 until the operating frequency is less than F5-06 minus F5-07. Refer to the diagram below.

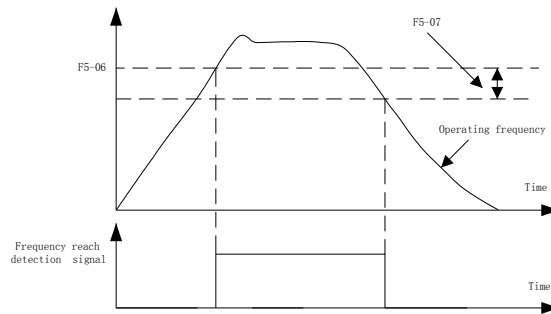

6.7 F6 Analog and pulse frequency terminals

F6-00	All input	Default	0	Change	○
--------------	------------------	---------	---	--------	---

6 FUNCTION DETAILS

Setting range	0: 0~10V or 0~20mA(corresponding to 0~100%) 1: 10~0V or 20~0mA(corresponding to 0~100%) 2: 2~10V or 4~20mA(corresponding to 0~100%) 3: 10~2V or 20~4mA(corresponding to 0~100%) 4: -10~10V or -20~20mA(corresponding to -100~100%) 5: 0~10V or 0~20mA(corresponding to -100~100%, with 5V or 10mA at the center) Note: The jumper on the control board chooses whether the input is a voltage-type or a current-type input.				
F6-01	AI1 gain	Default	100.0%	Change	○
Setting range	-999.9~999.9%				
F6-02	AI1 bias	Default	0.00%	Change	○
Setting range	-99.99~99.99%(10V or 20mA=100%)				
F6-03	AI1 filtering time	Default	0.100s	Change	○
Setting range	0.000~10.000s				
F6-04	AI2 input	Default	0	Change	○
F6-05	AI2 gain	Default	100.0%	Change	○
F6-06	AI2 bias	Default	0.00%	Change	○
F6-07	AI2 filtering time	Default	0.100s	Change	○
Setting range	All settings of AI2 are identical to those of AI1.				

 The table below lists the calculation formulas, characteristic curves and regulation diagrams for analog inputs(dotted lines represent factory settings while the solid ones represent regulated settings).

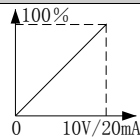
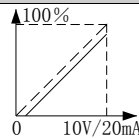
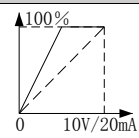
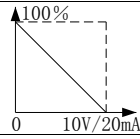
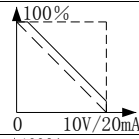
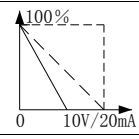
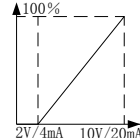
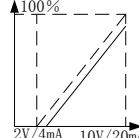
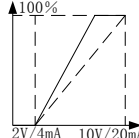
Input	Output calculation formula	Basic curve	Bias=10.00%	Gain=200.0%
0~10V or 0~20mA (corresponding to 0~100%)	Output = gain × (input-bias) (result limited to 0~100%)			
10~0V or 20~0mA (corresponding to 0~100%)	Output = gain × [-(input-bias) + 100%] (result limited to 0~100%)			
2~10V or 4~20mA (corresponding to 0~100%)	Output = gain × [5/4 × (input-bias) - 25%] (result limited to 0~100%)			

10~2V or 20~4mA (corresponding to 0~100%)	Output = gain × [-5/4 × (input-bias) + 125%] (result limited to 0~100%)			
-10~10V or -20~20mA (corresponding to -100~100%)	Output = gain × (input-bias) (result limited to -100~100%)			
0~10V or 0~20mA (corresponding to -100~100%, with 5V at the center)	Output = gain × 2 × [(input-bias) - 50%] (result limited to -100~100%)			

- A minus gain is valid only when F6-00=4 or 5.
- Increasing the filtering time will lower the response but strengthen the immunity against disturbance, while reducing it will raise the response but weaken the immunity.
- For the treatment of the analog input disconnection, refer to Fb-02.
- Related monitored parameters: FU-13 and FU-14.

F6-08	AO function	Default	1	Change	○
Setting range	1~12(see the table of analog output functions below)				
F6-09	AO type	Default	0	Change	○
Setting range	0: 0~10V or 0~20mA 1: 2~10V or 4~20mA 2: 5V or 10mA at the center				
F6-10	AO gain	Default	100.0%	Change	○
Setting range	0.0~1000.0%				
F6-11	AO bias	Default	0.00%	Change	○
Setting range	-99.99~99.99% (10V or 20mA=100%)				

Table of analog output functions:

- 1: Operating frequency(Max frequency=full-scale value)
- 2: Reference frequency(Max frequency=full-scale value)
- 3: Output current(2 times inverter rated current=full-scale value)
- 4: Output voltage(1.5 times inverter rated current=full-scale value)
- 5: Output capacity(2 times motor rated current=full-scale value)
- 6: PID feedback value
- 7: PID reference value
- 8: AI1
- 9: AI2
- 10: PFI(F4-02=0)
- 11: UP/DOWN value
- 12: DC bus voltage(1000V=full-scale value)

Setting range	0.0~100.0%
---------------	------------

The PFO function outputs the internal percentage signal in the format of pulse frequency or duty ratio, as shown below.

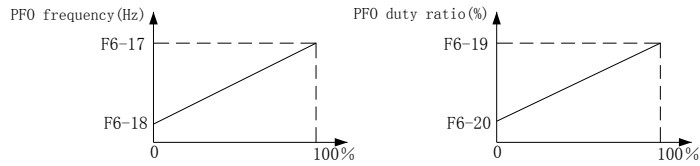

In frequency modulation(F6-16=0), the duty ratio is fixed at 50%. In duty-ratio modulation, the pulse frequency is fixed at the value set by F6-17.

6.8 F7 Process PID parameters

F7-00	PID control function	Default	0	Change	o
Setting range	0: Disabled 1: Enabled(PID output: Max frequency=100%) 2: PID corrects the reference frequency(PID output: Max frequency=100%)				

Process PID can be used for the control of process variables such as tension, pressure, flowrate, liquid level and temperature. The proportional(P) element can reduce the error. The integral(I) element can eliminate the static error. The longer the integral time, the weaker the integral action; and the shorter the integral time, the stronger the integral action. The differential(D) element can increase the response speed of the control. The structure of process PID is as follows.

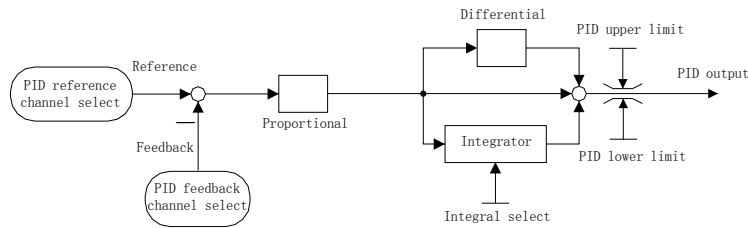

The PID regulation characteristic is determined by the polarity(plus or minus) of F7-04. Integral select is determined by F7-05.

Process PID can also correct the reference frequency prior to accel/decel slope. The method is adding PID output to the reference frequency. This function makes it convenient to use the inverter for master-slave synchronous control and closed-loop tension control, as shown in the following diagram.

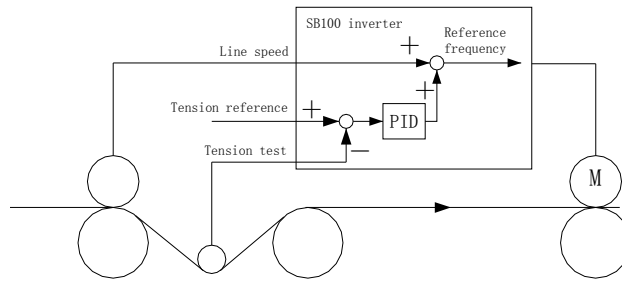

F7-01	PID reference channel select	Default	0	change	×
Setting range	0: F7-03 1: AI1 2: AI2 3: PFI(F4-02=0) 4: AI1-AI2 5: AI1+AI2 6: UP/DOWN value 7: Keypad POT 8: Communication				
F7-02	PID feedback channel select	Default	1	Change	×
Setting range	1: AI1 2: AI2 3: PFI(F4-02=0) 4: AI1-AI2 5: AI1+AI2 6: UP/DOWN value				
F7-03	PID digital reference	Default	0.0%	Change	○
Setting range	-100.0~100.0%				

📖 PID process adopts normalized input and output, that is, both the input and output range are between -100%~+100%. The input scaling is related to the settings of feedback channel select, sensor characteristics and analog input. The output scaling takes the maximum frequency as 100% for frequency control.

📖 There is a filtering section in the PID reference channel and feedback channel, for example, the filtering time for AI1 is F6-03. These filtering sections have influence on the control performance and can be set according to the actual needs.

📖 Related monitored parameters: FU-11 and FU-12.

F7-04	Proportional gain	Default	0.20	Change	○
Setting range	-99.99~99.99				
F7-05	Integral time	Default	20.00s	Change	○
Setting range	0.00~100.00s(0 indicates no integral)				
F7-06	Differential time	Default	0.000s	Change	○
Setting range	0.000~10.000s				

📖 If F7-04 is a plus value, the speed is required to rise with the increase of the reference, for example, in heating control. If F7-04 is a minus value, the speed is required to fall with the increase of the reference, for example, in cooling control.

📖 Principle of adjusting PID parameters: First raise the proportional gain from a smaller value(e.g. 0.20) until the feedback signal starts oscillating, then lower it by 40~60% to stabilize the feedback signal; reduce the integral time from a larger value(e.g. 20.00s) until the feedback signal starts oscillating, then

raise it by 10~50% to stabilize the feedback signal. Differential action can be introduced if there is a high requirement for overshoot and dynamic error.

F7-07	Sampling period	Default	0.010s	Change	○
Setting range	0.001~10.000s				

📖 The PID sampling period should normally be 5 to 10 times smaller than the response time of the controlled object.

F7-08	PID upper limit	Default	100.0%	Change	○
Setting range	-100.0%~100.0%(Max frequency=100%) Note: It must be greater than F7-09.				
F7-09	PID lower limit	Default	0.0%	Change	○
Setting range	-100.0%~100.0%(Max frequency=100%) Note: It must be less than F7-08.				

📖 Limiting the PID appropriately can suppress overshoot and avoid generating an overlarge controlling quantity.

F7-10	Multi-PID reference 1	Default	1.0%	Change	○
F7-11	Multi-PID reference 2	Default	2.0%	Change	○
F7-12	Multi-PID reference 3	Default	3.0%	Change	○
Setting range	-100.0~100.0%				

📖 Refer to digital inputs 20 and 21.

6.9 Fb Protection functions and advanced settings

Fb-00	Motor overload protection level	Default	100.0%	Change	○
Setting range	50.0~150.0%(motor rated current=100%)				
Fb-01	Motor overload protection action	Default	2	Change	×
Setting range	0: No action 1: Motor continues running with an alarm 2: Motor coasts to a stop due to the fault				

📖 Fb-00 is used to regulate the motor overload protection curve. Refer to the following diagrams.

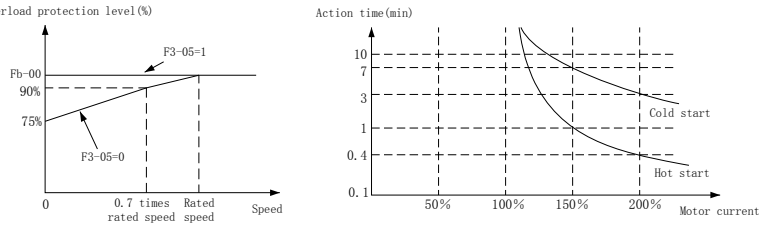

📖 Following the motor overload protection, the motor waits for some time to cool down before it continues to run.

⚠️ CAUTION: Motor overload protection is only suitable for applications where one inverter drives one

motor. For those applications where one inverter drives multiple motors, please install a thermal protector on each motor.

Fb-02	Analog input drop protection	Default	0	Change	×
Setting range	0: No action 1: Alarm AL.Aco is output 2: Motor runs at F0-00 with alarm AL.Aco 3: Motor coasts to a stop due to fault Er.ACo				

📖 This function is valid only when F6-00(or F6-04)=2 or 3. The analog input is considered to be dropped if the voltage(current) is less than 1V(2mA).

📖 Related parameters: F6-00 and F6-04.

Fb-03	Phase loss protection	Default	3	Change	×
Setting range	0: No action 1: Motor coasts to a stop with alarm Er.PLI(input phase loss) 2: Motor coasts to a stop with alarm Er.Plo(output phase loss) 3: Motor coasts to a stop(input & output phase loss)				

📖 Whether the input phase loss condition occurs or not is judged by the DC bus voltage ripples. When the inverter runs with no load or slight load, input phase loss might not be detected. When there is a great imbalance among the three input phases or the output oscialates seriously, input phase loss will be detected.

📖 Output phase loss protection can prevent the motor and mechanical load being damaged.

📖 Output phase loss protection is invalid if the output frequency or current is very low.

Fb-04	Overcurrent stall level	Default	110.0%	Change	×
Setting range	0.0~150.0%(0.0 means invalid. Inverter rated current=100%)				
Fb-05	Overvoltage stall level	Default	700V	Change	×
Setting range	0~750V(0 means invalid)				

📖 During acceleration (or constant-speed running), the motor stops accelerating(or begins decelerating) when the output current is greater than Fb-04, and restores to its original operating status after the current drops, as shown in the follwing diagrams (a) and (b).

📖 During deceleration, the motor stops decelerating when the DC bus voltage is greater than Fb-05, and continues decelerating after the DC bus voltage drops to the normal level, as shown in the diagram (c) below.

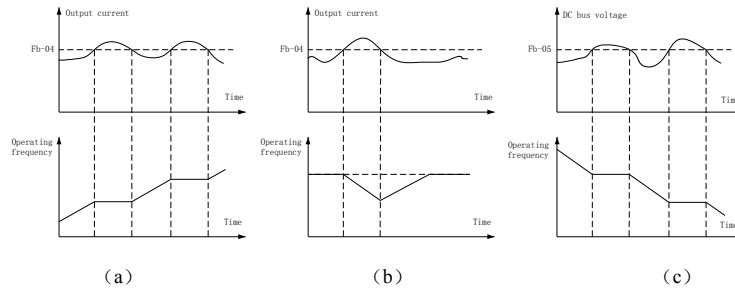

Fb-06	DC bus undervoltage protection	Default	0	Change	×
Setting range	0: Motor coasts to a stop due to fault Er.dcl 1: Motor coasts to a stop and restarts after power resumes				
Fb-07	DC bus underfoltage level	Default	400V	Change	×
Setting range	370~480V				

- ☞ When the DC bus voltage is lower than Fb-07, if Fb-06=0, the motor coasts to a stop and the alarm of DC bus undervoltage(Er.dcl) is given; or if Fb-06=1, the DC bus voltage slows down its drop and the motor restarts(according to F1-04) after power resumes.
- ☞ For large-inertia loads such as fans and centrifuges, setting Fb-06=1 can prevent undervoltage stop caused by momentary power failure.
- ☞ If undervoltage occurs during running, the motor coasts to a stop and the alarm Er.dcl is given; if it occurs in standby state, only the alarm AL.dcl is given.

Fb-08	Fault auto-reset times	Default	0	Change	×
Setting range	0~10				
Fb-09	Fault auto-reset interval	Default	5.0s	Change	×
Setting range	1.0~30.0s				
Fb-10	Fault output during auto-reset	Default	0	Change	×
Setting range	0: Not output 1: Output				

- ☞ The fault auto-reset function prevents trips caused by misoperation, instantaneous power overvoltage or external impact.
- ☞ Auto-reset procedure: When any fault occurs during running, following a period of time(Fb-09), auto-reset is performed automatically. If the fault is eliminated, the motor restarts according to the mode set by F1-04; if the fault still exist, and the reset times do not exceed Fb-08, the auto-reset will continue, otherwise, the motor will stop and give a fault alarm.
- ☞ Fault auto-reset times are cleared under the following conditions: No fault occurs for continuous ten minutes after fault auto-reset; manual reset is performed after the fault is detected; power resumes after power failure.
- ☞ Fb-10 determines whether the digital output 4(fault output) is valid during auto-reset.
- ☞ Faults of power device protection(Er.FoP) and external fault(Er.EEF) cannot be reset automatically.

⚠ DANGER : Be extremely careful while using the auto-reset function, otherwise injury to people or damage to equipment may occur.

Fb-11	Power-on auto start	Default	1	Change	○
Setting range	0: Disabled 1: Enabled				

- ☞ When terminal is the command source and F4-07=0, 1 or 2, this function selects whether the motor starts immediately after power-on

6 FUNCTION DETAILS

Fb-12	Built-in braking unit working point	Default	680V	Change	○
Setting range	620~720V				

- Using the braking unit can consume the energy on the braking resistor so as to stop the motor quickly. When the DC bus voltage exceeds Fb-12, the braking unit will start to work automatically.

Fb-13	Carrier frequency	Default	-	Change	○
Setting range	1.1k~16.0kHz Note: The factory settings are 2.5kHz for SB100-7.5/11T4, 3.5kHz for SB100-15/18.5T4, 3.0kHz for SB100-18.5/22T4, and 4.0kHz for other models.				
Fb-14	Carrier frequency auto regulation	Default	1	Change	○
Setting range	0: Disabled 1: Enabled				

- Increasing the carrier frequency can lower the motor noise, harmonic current and the heat generated by the motor, but raise the common-mode current, disturbance and the heat generated by the inverter, and decreasing the carrier frequency will lead to the opposite. Therefore, when a silent run is required, you can moderately raise the carrier frequency. If the carrier frequency is higher than the factory setting, the inverter should be derated by 5% for every increment of 1kHz.
- Fb-14 can regulate the carrier frequency automatically according to the heat-sink temperature, output current or output frequency, preventing the inverter failing due to overheating.

Fb-15	Cooling fan control	Default	0	Change	○
Setting range	0: Cooling fan stops after standby state lasts 3 minutes 1: Cooling fan keeps running				

- In applications where the motor starts/stops frequently, setting Fb-15 to 1 can prevent frequent start/stop of the cooling fan.

Fb-16	Jump frequency	Default	0.00Hz	Change	○
Setting range	0.00~625.00Hz				
Fb-17	Jumping width	Default	0.00Hz	Change	○
Setting range	0.00~20.00Hz				

- Jump frequency prevents the inverter running at the mechanical resonant points
- During acceleration or deceleration, the inverter can run through the jump frequency smoothly (i.e. jump frequency becomes invalid), but can not keep steady-state operation within the jumping width.

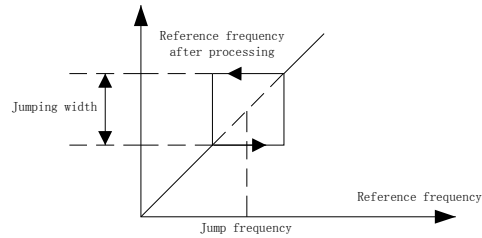

6.10 FC Keypad operation and display settings

FC-00	Monitored parameter 1(run & stop)	Default	1	Change	○
FC-01	Monitored parameter 2(run & stop)	Default	-1	Change	○
FC-02	Monitored parameter 3(run & stop)	Default	-1	Change	○
FC-03	Monitored parameter 4(run & stop)	Default	-1	Change	○
FC-04	Monitored parameter 1(run)	Default	0	Change	○
FC-05	Monitored parameter 2(run)	Default	2	Change	○
FC-06	Monitored parameter 3(run)	Default	4	Change	○
Setting range	-1~21(-1 indicates null, while 0~21 represent FU-00~FU-21 respectively) Note: FC-00 ranges from 0 to 21.				

☞ FC-00~FC-03 select(from the FU menu) the parameters to be displayed in both running and standby states.

☞ FC-04~FC-05 select(from the FU menu) the parameters to be displayed only in running state.

FC-07	Speed display coefficient	Default	1.000	Change	○
Change	0.001~10.000 Note: Only used for speed conversion, without any effect on actual speed and motor control FU-05=120×operating frequency÷pole number×FC-07 FU-06=120×reference frequency÷pole number×FC-07				
FC-08	Line speed display coefficient	Default	0.01	Change	○
Setting range	0.01~100.00 Note: Only used for speed conversion, without any effect on actual speed and motor control FU-09=operating frequency×FC-08 FU-10=reference frequency×FC-08				

6.11 FF Communication parameters

FF-00	Communication data format	Default	0	Change	×
Setting range	0: 8,N,1(1 start bit, 8 data bits, no parity check, 1 stop bit) 1: 8,E,1(1 start bit, 8 data bits, even check, 1 stop bit) 2: 8,O,1(1 start bit, 8 data bits, odd check, 1 stop bit) 3: 8,N,2(1 start bit, 8 data bits, no parity check, 2 stop bits)				
FF-01	Baud rate	Default	3	Change	×
Setting range	0: 1200bps 1: 2400bps 2: 4800bps 3: 9600bps 4: 19200bps 5: 38400bps				
FF-02	Local address	Default	1	Change	×
Setting range	1~247				
FF-03	Communication overtime detection time	Default	10.0s	Change	○
Setting range	0.1~600.0s				
FF-04	Communication overtime action	Default	0	Change	×
Setting range	0: No action 1: Alarm 2: Motor runs at F0-00 with alarm 3: Motor coasts to a stop due to fault				

☞ SB70 inverter's RS485 Modbus protocol comprises three layers: Physical layer, Data Link layer and

Application layer. The former two layers employ the RS485-based Modbus protocol. The application layer controls the run/stop of the inverter and the parameter reading and writing and so on.

- ☞ Modbus is a master-slave protocol. The communication between the master and slave falls into two types: master requests, slave responds; master broadcasts, slave doesn't respond. The master polls the slaves. Any slave can't send messages without receiving the command from the master. The master may resend the command when the communication is not correct. If the master doesn't get a response within given time, the slave polled is considered to be lost. The slave sends a piece of error information to the master if it can not implement a message.
- ☞ Communication only changes RAM values. If a parameter in RAM is to be written into EEPROM, the communication variable "EEP write command"(Modbus address is 3209H) needs to be changed to 1 by communication.
- ☞ Method of addressing the inverter parameters: among the 16 bits of the Modbus parameter address, the upper 8 bits represent the group number of a parameter, and the lower 8 bits represent the serial number of the same parameter in the group. For example, the address of the parameter F4-17 is 0511H. The group number is 50(32H) for communication variables(control word, status word, etc.).

Note: Communication variables include inverter parameters which can be accessed to by communication, as well as communication dedicated command variables and status variables. The menu codes correspond to the group numbers of parameters according to the following table.

Menu code	Parameter group No.	Menu code	Parameter group No.	Menu code	Parameter group No.	Menu code	Parameter group No.
F0	0 (00H)	F4	4 (04H)	Fb	8 (08H)	FP	12 (0CH)
F1	1 (01H)	F5	5 (05H)	FC	9 (09H)	FU	13 (0DH)
F2	2 (02H)	F6	6 (06H)	FF	10 (0AH)	—	—
F3	3 (03H)	F7	7 (07H)	Fn	11 (0BH)	—	—

- ☞ The data transmitted in communication are 16-bit integers. The minimum unit can be seen from the position of the radix point of the parameter. For example, the minimum unit of F0-00 is 0.01Hz, therefore, the data 5000 transmitted in communication represents 50.00Hz.

☞ Table of communication command variables

Name	Modbus address	Change	Description
Main control word	3200H	○	Bit 0: ON/OFF1(run on rising edge. 0: stop) Bit 1: OFF2(0: coast stop), digital input 9 priority Bit 2~3: Reserved Bit 4: Accel/decel enabled(0: accel/decel disabled), digital input 17 priority Bit 5~6: Reserved Bit 7: Fault reset(on rising edge), digital input 16 priority Bit 8: Jog forward, digital input 7 priority Bit 9: Jog reverse, digital input 8 priority Bit 10: Reserved Bit 11: Reference reversion(1: reference frequency reversed, 0: not reversed)

			Bit 12: Reserved Bit 13: UP/DOWN increase, digital input 10 priority Bit 14: UP/DOWN decrease, digital input 11 priority Bit 15: Process PID disabled, digital input 13 priority
Communication reference frequency	3201H	○	Non-negatives(unit: 0.01Hz)
Communication PID reference	3202H	○	Range: -100.00~100.00%
EEPROM write-in	3209H	○	When “1” is written into this address, the parameters in the inverter RAM will be written into EEPROM.

☞ Table of communication status variables

Name	Modbus address	Change	Description
Main status word	3210H	△	Bit 0: Ready(constant 1) Bit 8~9: Reserved Bit 1: Ready for run Bit 10: Frequency reach detection signal Bit 2: Running Bit 11~13: Reserved Bit 3: Fault Bit 14: Running forward Bit 4: OFF2 valid(0: valid) Bit 15: Reserved Bit 5: Reserved Bit 6: Charging contactor open Bit 7: Alarm
Operating frequency	3211H	△	Non-negatives(unit: 0.01Hz)
Load current percentage	3212H	△	Unit: 0.1%
PID feedback	3213H	△	Unit: 0.01%
Reference frequency	3214H	△	Non-negatives(unit: 0.01Hz)
Output current	3215H	△	Unit: 0.1A
PID reference	3216H	△	Unit: 0.01%
Output voltage	3217H	△	Unit: 0.1V
DC bus voltage	3218H	△	Unit: 0.1V
Fault code	3219H	△	Refer to Section 7.1
Alarm word	321AH	△	Refer to Section 7.2

☞ SB100 inverter supports the communication on a Modbus network using RTU(Remote Terminal Unit) mode. The functions it supports include: Function 3(read multiple parameters, with max. word number of 50) and Function 16(write multiple parameters, with max. word number of 10). Functions 16 supports broadcast(broadcast message address is 0). In RTU mode, both the starting and ending of the message frame are marked by an interval of at least 3.5 character times(but 2ms for baud rates of 19200bit/s and 38400bit/s). A typical RTU message frame is shown below.

Slave address (1 byte)	Modbus function code (1 byte)	Data (multiple bytes)	CRC16 (2 bytes)
---------------------------	----------------------------------	--------------------------	--------------------

☞ Function 3: Read multiple parameters. Word number read ranges from 1 to 50. Refer to the following example for its message format.

Example: Read the main status word, operating frequency and load current percentage(three words with their addresses beginning with 3210H) from the #1 slave.

Query from master:

Slave address	01H
Modbus function code	03H
Start address(MSB)	32H
Start address(LSB)	10H
Word number read(MSB)	00H
Word number read(LSB)	03H
CRC(MSB)	0AH
CRC(LSB)	B6H

Response from slave:

Slave address	01H
Modbus function code	03H
Byte number returned	06H
MSB of 3210H	44H
LSB of 3210H	37H
MSB of 3211H	13H
LSB of 3211H	88H
MSB of 3212H	00H
LSB of 3212H	00H
CRC(LSB)	5FH
CRC(MSB)	5BH

Function 16: Write multiple parameters. Word number written ranges from 1 to 10. Refer to the following examples for its message format.

Example 1: To make the #1 slave runs forward at 50.00Hz, you can rewrite the two words with their addresses beginning with 3200H into 003FH and 1388H.

Query from master:

Slave address	01H
Modbus function code	10H
Start address(MSB)	32H
Start address(LSB)	00H
Word number written(MSB)	00H
Word number written(LSB)	02H
Byte number written	04H
MSB of 1st data	00H
LSB of 1st data	3FH
MSB of 2nd data	13H
LSB of 2nd data	88H
CRC(LSB)	83H
CRC(MSB)	94H

Response from slave:

Slave address	01H
Modbus function code	10H
Start address(MSB)	32H
Start address(LSB)	00H
Word number written(MSB)	00H
Word number written(LSB)	02H
CRC(LSB)	4FH
CRC(MSB)	70H

Example 2: To make the #1 slave stop(forward run at 50.00Hz), you can rewrite the two words with their addresses beginning with 3200H into 003EH and 1388H.

Query from master:

Slave address	01H
Modbus function code	10H
Start address(MSB)	32H
Start address(LSB)	00H
Word number written(MSB)	00H
Word number written(LSB)	02H
Byte number written	04H
MSB of 1st data	00H
LSB of 1st data	3EH
MSB of 2nd data	13H
LSB of 2nd data	88H
CRC(LSB)	D2H
CRC(MSB)	54H

Response from slave:

Slave address	01H
Modbus function code	10H
Start address(MSB)	32H
Start address(LSB)	00H
Word number written(MSB)	00H
Word number written(LSB)	02H
CRC(LSB)	4FH
CRC(MSB)	70H

6.12 FP Fault history

 Refer to Section FP in Chapter 5.

6.13 FU Data monitoring

 Refer to Section FU in Chapter 5.

7 Troubleshooting

7.1 Faults and remedies

Fault display (fault code)	Fault type	Possible causes	Remedies
<i>Er.ocb</i> Er.ocb (1)	Overcurrent at start	Inter-phase or grounding short-circuit inside the motor or between wirings	Check the motor and wirings
		Inverting module damaged	Call us
		Voltage too high at start	Check the setting of "torque boost"
<i>Er.ocA</i> Er.ocA (2)	Overcurrent during acceleration	Accel time too short	Increase the accel time
		V/F curve improper	Adjust the V/F curve or the setting of "torque boost"
		Motor in revolution restarted	Set the start mode as "smooth start" Restart the motor after it stops completely
		Low power grid voltage	Check the input power
		Inverter capacity too small	Select an inverter with a larger capacity
<i>Er.occ</i> Er.occ (3)	Overcurrent during deceleration	Decel time too short	Increase the decel time
		The load is of potential energy type or has a large inertial torque	Install external dynamic braking unit
		Inverter capacity too small	Select an inverter with a larger capacity
<i>Er.occn</i> Er.occn (4)	Overcurrent during constant-speed running	Sudden change of Load	Reduce sudden change of the load
		Load error	Check the load
		Low power grid voltage	Check the input power
		Inverter capacity too small	Select an inverter with a larger capacity
<i>Er.ouA</i> Er.ouA (5)	Overvoltage during acceleration	Input voltage abnormal	Check the input power
		Motor in revolution restarted	Set the start mode as "smooth start" Restart the motor after it stops completely
<i>Er.oud</i> Er.oud (6)	Overvoltage during deceleration	Decel time too short	Increase the decel time
		The load is of potential energy type or has a large inertial torque	Install external dynamic braking unit
		Input voltage abnormal	Check the input power
<i>Er.oun</i> Er.oun (7)	Overvoltage during constant-speed running	Input voltage abnormal	Check the input power
		Accel/decel time too short	Increase accel/decel time
		Abnormal change of input voltage	Install an input reactor
<i>Er.ouE</i> Er.ouE (8)	Overvoltage in standby state	Input voltage too high	Check the input power
		Error of the test circuit for DC bus voltage	Call us

<i>Er.dcl</i> Er.dCL (9)	Undervoltage during running	Abnormal input voltage or power loss during running	Check the input power and wirings
		Impact of heavy load	Check the load
		Charging contactor damaged	Check and replace it
		Input phase loss	Check the input power and wirings
<i>Er.PLI</i> Er.PLI (10)	Input phase loss	Loss of phase R, S or T	Check the input wirings
		Imbalance among three input phases	Check the input voltage
		Serious oscillation of output	Regulate related parameters to eliminate the oscillation
<i>Er.PLo</i> Er.PLo (11)	Output phase loss	Loss of phase U, V or W	Check the output wirings Check the motor and cables
<i>Er.FoP</i> Er.FoP (12)	Power device protection	Output has inter-phase or grounding short-circuit	Rewire
		Loose connections or components on the control board	Check and rewire
		Connection wire between motor and inverter too long	Install an output reactor or filter
		Overcurrent of braking unit	Check the resistance and wiring of the external braking resistor
		Disturbance serious or inverter damaged	Call us
<i>Er.oHI</i> Er.oHI (13)	Inverter overheating	Ambient temperature too high	Lower the ambient temperature
		Air path blocked or cooling fan damaged	Clear the air path or replace the cooling fan
		Load too heavy	Check the load or select a large-capacity inverter
<i>Er.oLI</i> Er.oLI (14)	Inverter overload	Load too heavy	Check the load or select a large-capacity inverter
		Inverter temperature too high	Check the cooling fan, air path and ambient temperature
		Accel time too short	Increase the accel time
		Carrier frequency too high	Lower the carrier frequency or select an inverter with a larger capacity
		Motor in revolution restarted	Set the start mode as "smooth start" Restart the motor after it stops completely
		Input voltage too low	Check the input voltage
<i>Er.oLL</i> Er.oLL (15)	Motor overload	Improper V/F curve	Correctly set the V/F curve and "torque boost"
		Input voltage too low	Check the input voltage
		Long-term running of common motor at low speed and under heavy load	Install a separate cooling fan or select a special motor for the inverter

		Improper setting of motor nameplate parameters or overload protection	Correctly set F3-02, F3-05 and Fb-00
		Motor stall or sudden and great change of load	Check the load
<i>Er.EEF</i> Er.EEF (16)	External fault	External fault terminal valid	Remove the external fault
<i>Er.CFE</i> Er.CFE (17)	Communication overtime	Improper setting of communication parameters	Check the settings of the FF menu
		Communication disturbance serious	Check the wiring and grounding of the communication circuit
		PC not work	Check the PC and wiring
<i>Er.ccf</i> Er.ccf (18)	Current test fault	Loose connections or components inside the inverter	Check and rewire
		Current sensor damaged or circuit abnormal	Call us
<i>Er.Aco</i> Er.Aco (19)	Analog input drop	Wiring broken or peripheral damaged	Check external wirings and peripherals
<i>Er.rHo</i> Er.rHo (20)	Thermal resistor open	Thermal resistor disconnected	Check the wiring for the thermal resistor or call us
<i>Er.Io1</i> Er.Io1 (21)	Reserved	—	—
<i>Er.Io2</i> Er.Io2 (22)	Reserved	—	—

7.2 Alarms and remedies

Alarm display	Alarm name	Description	Remedies	Alarm word bit
<i>AL.oLL</i> AL.oLL	Motor overload	The motor thermal model detects that the motor temperature rise is overhigh	Refer to above table	Bit 0
<i>AL.Aco</i> AL.Aco	Analog input drop	The analog input signal is lower than the drop threshold	Refer to above table	Bit 1
<i>AL.CFE</i> AL.CFE	Communication overtime	—	Refer to above table	Bit 2
<i>AL.EEP</i> AL.EEP	Parameter store failed	—	Press  to clear. Turn power off and retry. If the alarm appears again, call us for help.	Bit 3
<i>AL.dcL</i> AL.dcL	DC bus undervoltage	The DC bus voltage is lower than the undervoltage level	It is normal for this alarm information to be displayed when the power is off	Bit 4

AL.PcE AL.PcE	Parameter check error	Improper parameter setting	Press  to clear. Correct the parameter setting or restore it to the factory setting	Bit 5
------------------	-----------------------	----------------------------	--	-------

7.3 Operation faults and remedies

Operation fault	Description	Possible causes	Remedies
No key-press response	Some or all keys have no response to key pressing	Poor contact of the keypad connecting wire	Check the connecting wire or call us
		Keys are damaged	Replace the keypad
Parameter correction failed	Parameters cannot be modified	They are read-only ones	Read-only parameters are unchangeable
	Parameters cannot be modified in running state	They are unchangeable in running state	Modify them in standby state
Unexpected stop during running	Inverter stops without receiving stop command(run LED off)	Fault exists	Troubleshoot and reset the fault
		Command source is switched	Check the command source
	Inverter stops without receiving stop command(run LED on)	Waiting for the fault auto-reset	Check the setting of fault auto-reset
		Reference frequency is zero	Check the reference frequency
		Output frequency is too low under PID control	Check the PID reference and feedback
Waiting for the restart after momentary power failure	—		
Start failed	Upon receiving start command, the inverter does not start and the run LED is off	Digital input 9 is valid	Check the terminal of “coast stop/run disabled”
		In the control modes of 3-wire 1, 2 or 2-wire 3, the stop button is not closed	Check the stop button and its wiring
		Command source error	Change the command source
		Inverter error	Eliminate the error

8 Maintenance and After-sale service



- 1. Only professionally trained persons can disassemble and repair the inverter and replace its parts.**
- 2. Make sure the power supply of the inverter is cut off, the high-voltage indicator goes out and the voltage between P+ and N- is less than 36V before checking and repairing the inverter, otherwise there may be a risk of electric shock.**
- 3. Do not leave any metal pieces such as screws and washers in the inverter. That may destroy the inverter or cause fire.**
- 4. Reset related parameters after replacing the control board, otherwise the inverter may be destroyed.**

8.1 Daily maintenance

Due to factors of dust, humidity, vibration, aging, etc., faults would occur over time. It is necessary to check the inverter and its working environment regularly in order to extend the lifespan of the inverter.

Check points:

1. If the working environment of the inverter meets the requirement.
2. If the operating parameters of the inverter are set within the specified ranges.
3. If there is any unusual vibration or noise.
4. If there is any unusual odor.
5. If the fans run normally.
6. If the input voltage is within the specified range and voltages of various phases are balanced.

The periodical maintenance should be performed once every three or six months according to the service conditions. Check points:

1. If the screws of control terminals are loose.
2. If the main circuit terminals have a poor contact and the copperplate connections have traces of overheating.
3. If the power and control cables are damaged.
4. If the insulated binding band for the cold-pressed terminals of the power cables comes off.
5. Remove dust on PCBs and wind path thoroughly. It's better to use a vacuum cleaner.
6. When leaving the inverter unused for a long term, check it for functioning once every two years by supplying it with electricity for at least five hours with the motor disconnected. While supplying the power, use a voltage regulator to raise the voltage gradually to the rated value.

8.2 Replacement of parts

◆ Cooling fan

Causes of damage: wear of bearings; aging of blades(average life is 30 to 40 thousand hours).

Judging criterion: crack in blades, etc.; unusual vibration at the start.



1. While replacing the fan, use the fan model designated by the factory(with identical rated voltage, current, speed and air volume).
2. While installing the fan, be careful that the direction marked on the fan must conform to direction in which the fan supplies wind.
3. Do not forget to install the fan guard.

◆ Electrolytic capacitor

Causes of damage: high ambient temperature; frequent and sudden load change which leads to high pulsating current; aging of electrolyte.

Judging criterion: protrusion of safety valve; measurement of static capacitance; measurement of insulation resistance.

It is recommended to replace the bus electrolytic capacitor once every four or five years.

8.3 Storage of the inverter

- ◆ Avoid storing the inverter in a place with high-temperature, humidity, dust and metal powder.
- ◆ Leaving the inverter unused for a long period would lead to aging of the electrolytic capacitors. So the inverter must be supplied with electricity once every two years for at least five hours, and the input voltage raised gradually through a regulator to the rated value.

8.4 After-sale service

The warranty period is one year from the purchase date. However, the repair cost should be born by the user for the following damages even within this term.

1. Damage caused by operation not in accordance with the user's manual.
2. Damage caused by unauthorized repairs or modifications.
3. Damage caused by using the inverter beyond the standard specifications.
4. Damage caused by falling or an accident during transportation after the purchase.
5. Damage cause by fire, flood, abnormal voltage, lightning strike, etc.

- **The contents of this manual are subject to change without notice**

Hope SenLan Science & Technology Holding Corp.,Ltd

Add: 181 Airport Road, Chengdu, P.R.China (610225)

Web: <http://www.chinavvf.com>

E-mail: markd@chinavvf.com

Tel: 86-28-85964751

Fax: 86-28-85962488